MEDIUM VOLTAGE DRIVES

ACS2000, 4 kV

User manual



Table of content

004–012	General information on manual and equipment
013–019	Safety
020–037	Power electronics and cabinet features
038–052	Control system
053–056	Transportation, storage and disposal
057–063	Mechanical installation
064–073	Electrical installation
074–075	Commissioning
076–084	Local operation
085–095	CDP Control panel
096–111	Troubleshooting and maintenance

General information on manual and equipment

Copyright notice

The information in this manual is subject to change without notice.

This manual and parts thereof must not be reproduced or copied, or disclosed to third parties, nor used for any unauthorized purpose without written permission from ABB Inc., Medium Voltage Drives.

The hardware described in this manual is provided under a license and may be used, copied, or disclosed only in accordance with the terms of such license.

Document identification

- Ownership: ABB Inc.
- Document number: 2UEA001270
- Revision index: F
- Issue date: 04.01.2014

Equipment covered by the manual

Table 1: Identifying the drive frame

Frame	Normal duty range kW [hp]	Drive type code (first 11 positions)
1	224-746 [300-1000]	ACS2040-1x-
2	933-1492 [1250-2000]	ACS2040-2x-
3	1697-2238 [2250-3000]	ACS2040-3x

This manual covers standard equipment and provides generic information on the equipment. The manual does not claim to cover all variations and details of the equipment, nor to consider all eventualities that may arise during installation, commissioning, operation and maintenance of the equipment.

If the equipment is adapted to specific customer needs or applications, and handling, installation and operation of the equipment are affected by these modifications, information on these modifications is provided in the appropriate documentation (e.g. layout drawings, wiring diagrams, technical data, engineering notes).

If information is required beyond the instructions in this manual refer the matter to ABB. See section Contact information.

Structure of the user documentation

The complete set of user documentation of a standard drive consists of this manual and supplementary documentation that is provided in the following appendices, located on the CD:

Appendix A - ACS2000 Maintenance schedule	Recommended maintenance service schedule
Appendix B - Fieldbus adapter manuals	Manuals about fieldbus interfaces
Appendix C - Technical data	Technical data sheets of the drive
Appendix D - Mechanical drawings	Outline drawing(s) of the equipment
Appendix E - Wiring diagrams	Circuit diagrams with information on device designation, cross-reference and device-identification conventions. The diagrams are generated according to the customer-specific project
Appendix F - Spare parts manual	This parts manual is generated for each drive. Includes all information necessary to identify a component
Appendix G - MV switchgear guide	Provides detailed information on the MV (Medium Voltage) switchgear
Appendix H - Cable specifications	Power cable specifications for drive connections
Appendix I - Kirk key specifications	Kirk® key interlock specifications
Appendix K - Pulse encoder	Pulse encoder specifications
Appendix L - Motor temperature supervision	Motor temperature supervision information
Appendix M - Signal and parameter table	Descriptions of actual signals, control and status words, and control parameters and their default settings
Appendix N - Troubleshooting guide	Information on the root cause of an alarm or fault and provides hints for corrective measures
Appendix O - DriveMonitor™ 3000 user manual	Provides instructions for remote monitoring
Appendix P - Integral input contactor disconnect operation guide	Provides detailed information on the integral input contactor disconnect option

Contact information

Address: ABB Inc.
Medium Voltage Drives
16250 W. Glendale Drive
New Berlin, WI 53151

Phone: 262-785-2877
Fax: 262-785-3322
Email: mv.drives.sales@us.abb.com
www.abb.us/drives

Global: www.abb.com

Target groups and required qualifications

The equipment presented in this manual is part of an industrial environment where voltages are present that contain a potential hazard of electric shock, burn, physical injury and/or death. For this reason, only personnel who have a thorough knowledge of the equipment and the industrial environment and have obtained the required qualification should handle, install, operate or maintain the equipment.

The manual addresses personnel who are responsible for unpacking, transportation, installation, operation and maintenance of the equipment. The personnel must carry out the below listed tasks in a manner that does not cause physical harm or danger and ensures the safe and reliable function of the equipment.



Note: Commissioning of drive equipment must only be performed by qualified and certified ABB personnel.

Handling

Personnel must be skilled and experienced in unpacking and transporting heavy equipment.

Mechanical installation

Personnel must be qualified to prepare the installation site according to the site and equipment requirements and to perform the installation accordingly.

Electrical installation

Personnel must have a sound knowledge of the relevant electrical codes and specifications covering low and medium voltage equipment, be experienced with electrical wiring principles and understand the electrical symbols typically used in wiring diagrams.

Operation

Personnel include all persons who operate the equipment as required for the specified application. Personnel must know the driven process and be adequately trained to operate the equipment. Special knowledge of frequency converter technology is not required.

Maintenance

Personnel must be thoroughly familiar with the construction of the equipment, be adequately trained to check the equipment and to perform the scheduled service and maintenance tasks. Personnel must know the safe shutdown and grounding procedures for the equipment.

Table 2: Relevant chapters of the manual

Chapter	Handling	Installation	Operation	Maintenance
General information	x	x	x	x
Safety	x	x	x	x
Power electronics and cabinet features, Overview			x	x
Transportation	x			
Mechanical installation		x		x
Electrical installation		x		
Operation			x	
Troubleshooting and maintenance				x

User's responsibilities

It is the responsibility of those in charge of the equipment to ensure that each person involved in the installation, operation or maintenance of the equipment has received the appropriate training and has thoroughly read and clearly understands the instructions in this manual and the relevant safety instructions.

Intended equipment use

Those in charge of the equipment must ensure that the equipment is used as specified in the contractual documents, operated under the conditions stipulated in the technical specifications and on the rating plate of the equipment, and serviced in the intervals as specified by ABB.

Unauthorized modifications and constructional changes of the equipment are not permitted.

Quality certificates and applicable standards

The following certificates and conformity declarations are available with ABB:

- ISO 9001/ISO 14001 certificates stating that ABB Inc. has implemented and maintains a management system that fulfills the requirements of the normative standards
- EC Conformity Declaration
- Standards and certifications EN, IEC, CE and cUL.
Meets IEEE 519 and IEC 61000-2-4

Trademarks

Names that are believed to be trademarks of other companies and organizations are designated as such. The absence or presence of such a designation should, however, not be regarded as an offense to the legal status of any trademark. The following registrations and trademarks are used in this manual:

Windows®	Registered trademark of Microsoft Corporation
Industrial IT™	Trademark of ABB
DriveWare®	Registered trademark of ABB
DriveMonitor™	Trademark of ABB
Ethernet®	Registered trademark of Xerox Corporation
Profibus®	Registered trademark of Profibus International (P.I.)
ControlNet®	Registered trademark of ControlNet International, Ltd.
Modbus®	Registered trademark of the Modbus ICA organization
DeviceNet®	Registered trademark of the Open DeviceNet Vendor Association, Inc.
Kirk® key	Registered trademark of the Kirk Key Interlock Company
Anybus®	Registered trademark of HMS Industrial Networks, Inc.
3M Scotch-Brite™	Registered trademark of 3M

Writing conventions

The following icons and text conventions are used in the manual.





	Illustrates an illuminated pilot light or pushbutton
	Illustrates a button or key to be pressed
	Arrows indicate an alternating display message
	Refers to further information in a separate document
• Bulleted list	Used to list items or steps in a procedure, where the sequence does not matter
- Bulleted list of a subsection following a main paragraph	Used to list items or for procedures, where the sequence does not matter
1.	Steps of a procedure to be followed in the specified order
— 01	Figure legend, numbers identify the items referred to in the illustration above
Bold	Used to highlight switches to be operated, status messages shown in a display and special terms
UPPERCASE	Refer to a parameter
<i>Italic</i>	Used for references to illustrations, chapters and supplementary documentation

Illustration conventions

Frame 1, ACS2000 4k V, is used for general layout and location photos unless expressly stated. The electrical layout, the physical order, and the topology are shared between all frames.

- Terminal Entry Unit (TEU) and LV Control Unit (COU) are shared with all frames, left bay
- The Input Filter Unit (IFU), filter bay, grows to accommodate the higher current for each frame
- The INverter Unit (INU) and power modules, right bay, grow to accommodate the higher current for each frame

Meaning of terms and abbreviations

The following table lists terms and abbreviations you should be familiar with when using the manual. Some of the terms and abbreviations used in the manual are unique to ABB and might differ from the normal usage.

Term/Abbreviation	Meaning
AFE	Active Front End. The AFE, also referred to as ARU (Active Rectifier Unit), is the line-side rectifier of the drive that enables optional four-quadrant operation and reactive power compensation
AMC circuit board	Application and Motor Controller. The digital signal processor is the heart of the control system of the drive. A separate AMC circuit board is assigned to the line-side rectifier (AFE) and the motor inverter (INU) of the drive
CDP	Control/Display Panel. Removable controller of the drive located on the exterior of the terminal entry unit door
Converter	Short form for ACS2000 frequency converter
COU	Short form for controls unit compartment of the drive. It contains control boards, circuit breakers, relays and the IOEC modules
DC	Direct current
DC link	The DC link consists of the capacitor, the charging unit and the grounding switch. Energy is absorbed and stored in the DC link capacitor for distribution
DDCS	Distributed drive control system. DDCS is an acronym for a fieldbus communication protocol designed for data transfer via fiber-optic cables
Drive	Short form for ACS2000 frequency converter
Drive system	The drive system includes all equipment used to convert electrical into mechanical power to give motion to the machine
DriveBus	Communication link dedicated for ABB drives
DriveDebug	DriveDebug is part of ABB's DriveWare [®] software tools for drives using the DDCS communications protocol. DriveDebug runs on computers with Windows [®] operating systems. DriveDebug is a specialist's tool used to diagnose, tune and troubleshoot ABB drives
DriveWindow	DriveWindow is a DriveWare [®] product. DriveWindow is a Windows [®] application for commissioning and maintaining ABB drives equipped with fiber-optic communication
DriveMonitor™	DriveMonitor is a monitoring and diagnostics system that allows secure access to the drive via the internet from a remote location. DriveMonitor provides long-term monitoring functions that allow the user to read/display equipment status and improve equipment performance
EMC	Electromagnetic compatibility. All measures to suppress electromagnetic disturbances caused by different electrical equipment in the same electromagnetic environment, and to strengthen the immunity of the equipment to such disturbances
Equipment	ACS2000 and related equipment
Ground	Earth

Term/Abbreviation	Meaning
To ground	The conducting path (e.g. conductor) between the electric equipment (e.g. frequency converter) and the earth. The electric equipment is connected to the earth, e.g. by a grounding set or a grounding switch
IFU	Input filter unit. The IFU is a tuned filter: inductors, resistors and capacitors that reduce harmonic voltages injected to the supply network
INT	Interface
INU	Inverter unit of the drive. The INU converts the DC voltage to the required AC motor voltage and frequency
IOEC module	Term of ABB's I/O system. The I/O module is an active input or output device for digital or analog signals
LED	Light emitting diode
Line voltage	RMS voltage of the main power supply of the drive – line to line
LV	Low voltage
MCB	MV switchgear
MV switchgear	Medium voltage switchgear isolation device. The MV switchgear is a mandatory inter-connection device of the drive system and connects / disconnects the main power supply to the drive. The MV switchgear must be controlled entirely by the drive
NP	Neutral point
PCB	Printed circuit board
PE	Protective earth
Phase module	The phase module is a compact assembly of wired components including power semiconductors and circuit boards that serves as a standardized building block for the AFE and INU of the drive
PPCS	Power plate communication system. PPCS is an acronym for a fieldbus communication protocol designed for high speed data transfer via fiberoptic cables between the AMC circuit board and phase INTerface circuit boards
RTD	Resistance temperature detector or device. The RTD is a temperature sensor where the change in electrical resistance is used to measure the temperature
Safeline	ABB synonym for uninterruptible power supply
TEU	Short form for terminal entry unit of the drive
Zero speed threshold	Used in the manual to indicate that the drive has reached the value “zero speed” that is set in a parameter. The value can be set in the range from 0 to maximum speed (speed is measured in rpm)

Related documentation

The following documents are available for supplementary information:

Title	Document number	Location
Modbus - NMBA-01 installation and start-up guide	3AFY58919772	Appendix B
Ethernet - user manual ethernet adapter module NETA-01	3AFE64605062	Appendix B
Profibus - NPBA-12 installation and start-up guide	3BFE64341588	Appendix B
Anybus DeviceNet module – user manual		
Anybus EtherNet IP module – user manual		
Anybus ControlNet module – user manual		
Spare parts list		Appendix F
MV switchgear guide	2UEB000132	Appendix G
Power cable specification	2UEB000093	Appendix H
Pulse encoder (NTAC-01) manual	3AFY58919730	Appendix K
Motor temperature supervision	2UEB000133	Appendix L
Troubleshooting guide. The troubleshooting guide provides information on the root cause of an alarm or fault and provides hints for corrective measures.		Appendix N
DriveMonitor 3000 user manual	3BHS268039	Appendix O
Integral input contactor disconnect operation guide	2UEB000245	Appendix P
Induction motor specification	2UEA000091	
Service and maintenance manual	2UEB000096	
Preventive maintenance manual	3BHS248911	
Warranty directives	3BHS404420 ZAB E01	

—
01
Items covered by
delivery - Frame 1

Items covered by delivery - Frame 1

Delivery typically comprises the following items
(see Figure 1 - Frame 1).

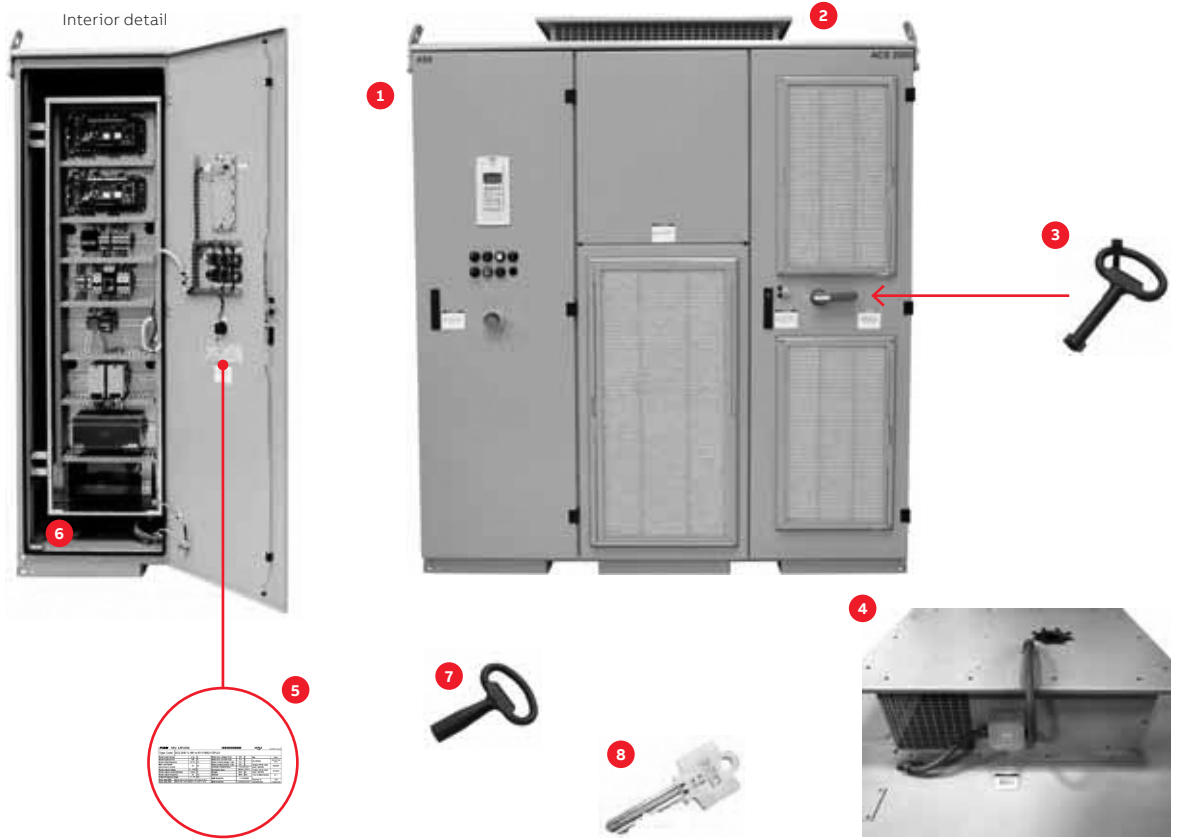

1	Drive	Shipped in either overland or sea freight packaging
2	Fan outlet box	Installed on the drive
3	LV (low voltage) compartment door key	Shipped zip tied to the grounding switch handle
4	Redundant fan (option)	Installed on the drive when this option is selected
5	Rating label	Drive identification
6	Document pouch	The document pouch contains the Kirk® key, the MV (medium voltage) compartment door key and important documents. The document pouch is located inside the control compartment
7	MV (medium voltage) compartment door key	Shipped in the document pouch located inside the control compartment
8	Kirk key	Shipped in the document pouch located inside the control compartment

—
02
Items covered by
delivery - Frame 2

Items covered by delivery - Frame 2

Delivery typically comprises the following items
(see Figure 2 - Frame 2).

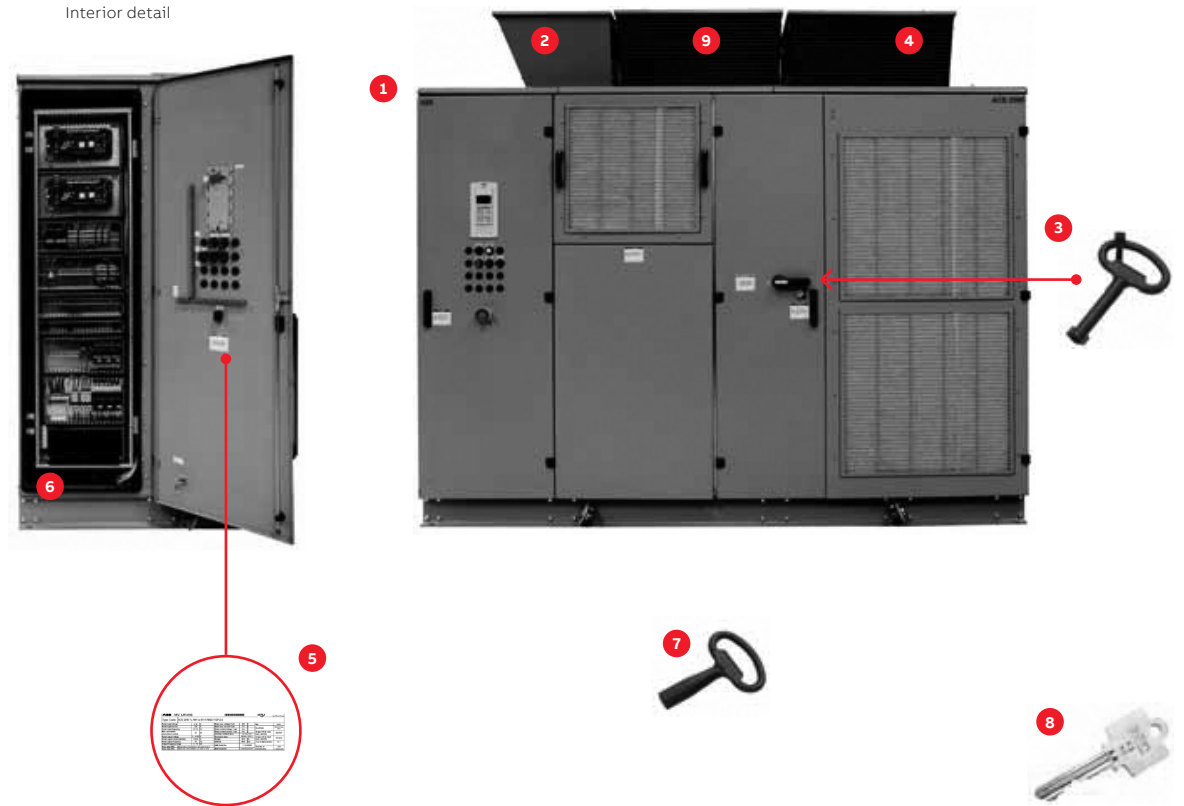

1	Drive	Shipped in either overland or sea freight packaging
2	Fan outlet box	Installed on the drive
3	LV (low voltage) compartment door key	Shipped zip tied to the grounding switch handle
4	Redundant fan (option)	Installed on the drive when this option is selected
5	Rating label	Drive identification
6	Document pouch	The document pouch contains the Kirk® key, the MV (medium voltage) compartment door key and important documents. The document pouch is located inside the control compartment
7	MV (medium voltage) compartment door key	Shipped in the document pouch located inside the control compartment
8	Kirk key	Shipped in the document pouch located inside the control compartment
9	Standard fan	Installed on the drive

—
03
Items covered by
delivery - Frame 2

Items covered by delivery - Frame 3

Delivery typically comprises the following items
(see Figure 3 - Frame 3).

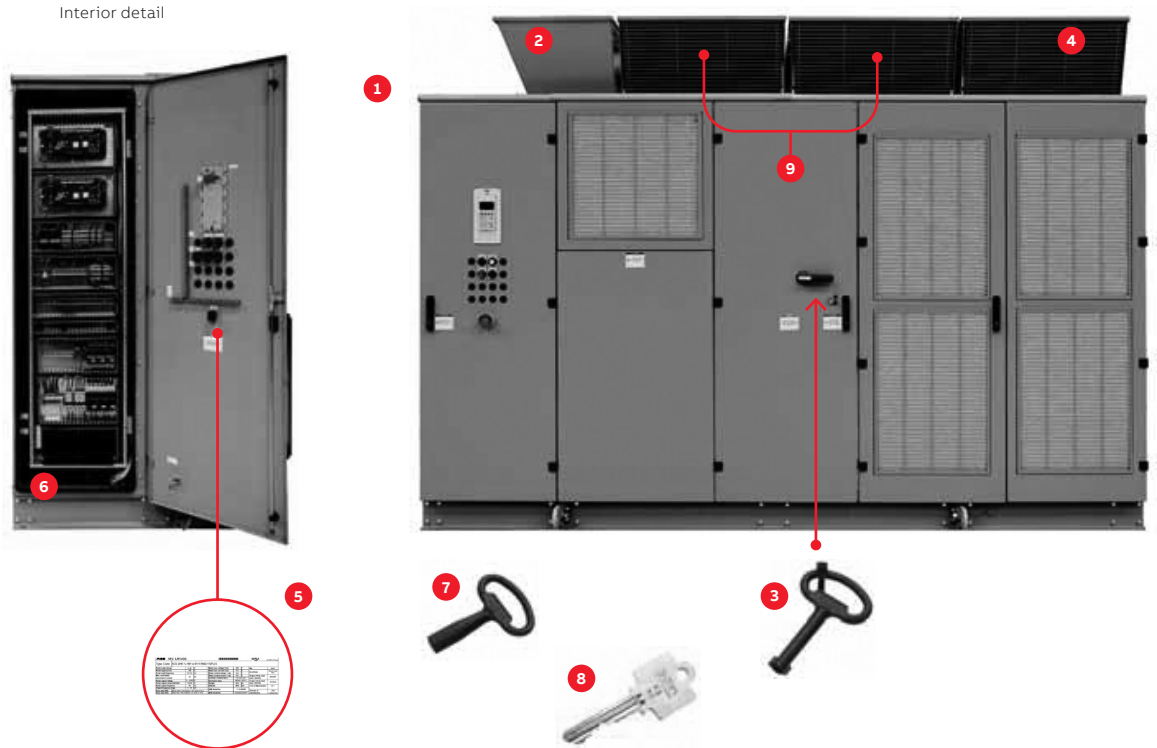

1	Drive	Shipped in either overland or sea freight packaging
2	Fan outlet box	Installed on the drive
3	LV (low voltage) compartment door key	Shipped zip tied to the grounding switch handle
4	Redundant fan (option)	Installed on the drive when this option is selected
5	Rating label	Drive identification
6	Document pouch	The document pouch contains the Kirk® key, the MV (medium voltage) compartment door key and important documents. The document pouch is located inside the control compartment
7	MV (medium voltage) compartment door key	Shipped in the document pouch located inside the control compartment
8	Kirk key	Shipped in the document pouch located inside the control compartment
9	Standard fan	Installed on the drive

Identifying the delivery

The drive and accessories are identified by the type code printed on the rating label (see item 5 in Figure 1, 2 or Figure 3 and Table 3).

—
Table 3: Identifying the drive frame

Frame	Normal duty range kW [hp]	Drive type code (first 11 positions)
1	224-746 [300-1000]	ACS2040-1x-
2	933-1492 [1250-2000]	ACS2040-2x-
3	1697-2238 [2250-3000]	ACS2040-3x

The rating label is located on the back of the COU (control compartment) door.

Besides information on equipment identification, the label provides important information on rated voltage, frequency and current of the main and the auxiliary power supply.

Tools

ABB offers various tool sets containing all necessary tools and equipment for installation, commissioning and maintenance of the drive.

Safety

Meaning of safety instructions

Safety instructions are used to highlight a potential hazard when working on the equipment. Safety instructions must be strictly followed! Non-compliance can jeopardize the safety of personnel, the equipment and the environment.



DANGER indicates a hazardous situation which, if not avoided, will result in death or serious injury.



WARNING indicates a hazardous situation which, if not avoided, could result in death or serious injury.



CAUTION indicates a hazardous situation which, if not avoided, could result in minor or moderate injury.



NOTICE is used to address practices not related to personal injury.

The safety instructions are derived from the following standards:

- ISO 3864-2:2004 (E)
Graphical symbols – Safety colors and safety signs – Part 2: Design principles for product safety labels
- ANSI Z535.6
American National Standard for Product Safety Information in Product Manuals, Instructions, and Other Collateral Materials

General safety information

To maintain safety and minimize hazards, observe the following:

- Before the drive is energized, make sure that:
 - all foreign objects are removed from the drive
 - all internal and external covers are securely fastened and all doors are closed, locked and / or bolted
- Before starting to work on the drive, make sure that:
 - the main and auxiliary power supply to the drive is switched off. Locked out, and tagged out
 - the drive is de-energized and the DC bus is discharged
 - safety ground connections are in place
 - appropriate personal protective equipment is provided and used when required
 - everyone involved is informed
- Near the running drive, workers should wear protective earmuffs
- Before work is carried out simultaneously on the drive and on other drive system equipment, make sure that:
 - the relevant safety codes and standards are observed
 - all energy sources for the equipment are turned off
 - lockout and tagout devices are in place
 - barriers and appropriate covers are used on equipment which is still live
 - everyone involved is informed
- In case of fire in the drive room:
 - Observe the established rules and regulations for fire protection
 - Only firemen with appropriate protective equipment are allowed to enter the drive room

Possible residual risks

The following risks can arise from a drive system and pose a hazard to people. These risks must therefore be taken into account by the system integrator and / or the plant owner when assessing the risks of the machinery.

- Electric power equipment generates electromagnetic fields which can cause a hazard to people with metal implants and / or a pacemaker
- Drive system components can move unintentionally when being commissioned, operated, or serviced due to, for example:
 - Operation of the equipment outside the scope of the specifications
 - Incorrectly assembled or installed equipment
 - Incorrectly connected cables
 - External influence on, or damage to the equipment
 - Wrong parameter settings
 - Software errors
 - Faulty hardware
- Hazardous voltages can be present on drive system components caused by, for example:
 - Operation of the equipment outside the scope of the specifications
 - External influence on, or damage to the equipment
 - Induced voltages by external equipment
 - Condensation on equipment components, or pollution
 - Faulty hardware
- High temperatures, noise, particles, or gases can be emitted from drive system components caused by, for example:
 - Operation of the equipment outside the scope of the specifications
 - External influence on, or damage to the equipment
 - Wrong parameter settings
 - Software errors
 - Faulty hardware
- Hazardous substances can be emitted from drive system components due to, for example:
 - Incorrect disposal of components

Safety labels and signs**Safety labels**

Safety labels are attached to the cabinet where necessary to alert personnel of potential hazards when operating or working on the equipment. It is important to read and understand these labels. The instructions on the safety labels must always be followed. The labels must be kept in place and legible.

A label that is damaged or missing must be replaced. Contact ABB for replacement.

Label identification

The safety labels are identified by means of a number printed in the footer of the safety label.



The last two digits of the safety label number identify the language of the label text. In Figure 04, for example, the last two digits 09 identify English.

—
05
Front of unit label
locations

Label location

Figures 05 and 06 indicate the placement of safety labels on the drive.

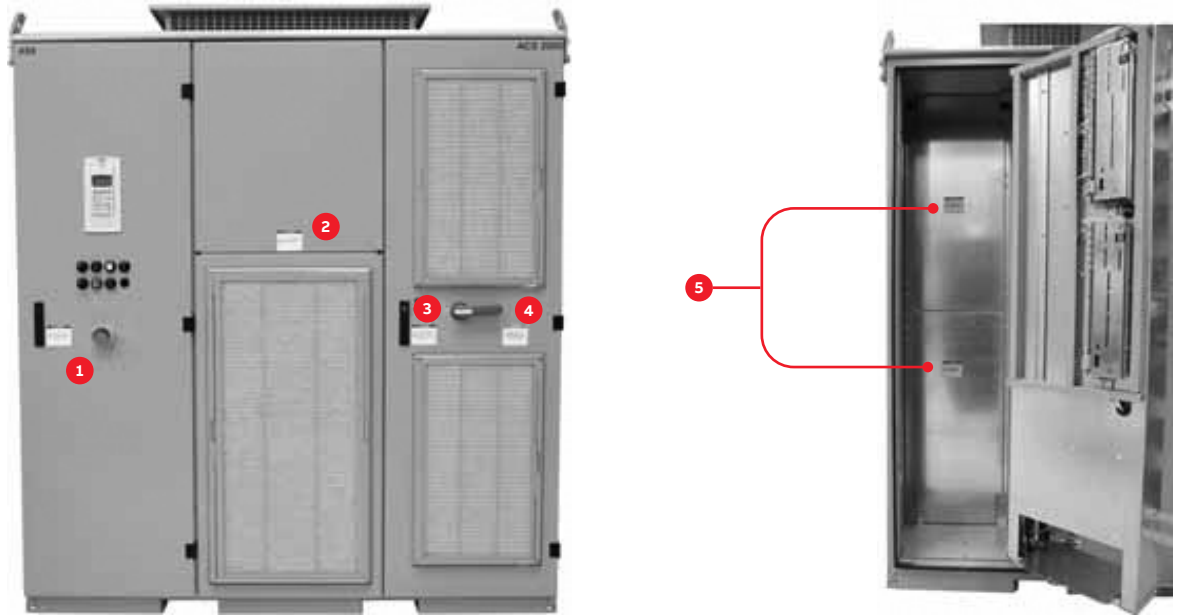

Item	Label number	Label description
1	2UEA001524T00XX	Danger – Risk of Electric Shock. More than one disconnect switch may be required to de-energize equipment before servicing
2	2UEA001528T00XX	Danger – HIGH VOLTAGE Unauthorized Persons KEEP OUT
3	2UEA001525T00XX	Danger – Risk of Electric Shock. Disconnect power, allow 7 minutes for capacitors to discharge and ground equipment before opening door
4	2UEA001634T00XX	Notice – Ground Switch is locked when the “GROUND SW RELEASED” pilot light is OFF. To ground equipment, the pilot light must be ON before rotating the handle to grounded (O) position
5	2UEA001526T00XX	Danger – This Equipment does not provide isolation. Separate isolating means required. See Section Isolating means (MV Switchgear) and Appendix G - MV switchgear guide, located on the CD, for additional information

—
06
Top, back and side of
unit label locations

—
07
Fire fighting sign

—
08
Heart pacemaker sign

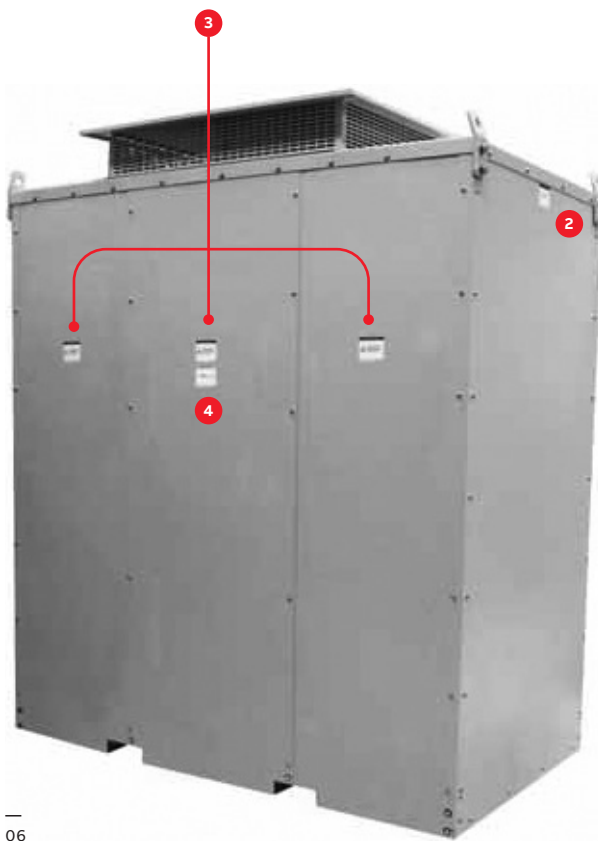

—
06

Item	Label number	Label description
1	3BHB017195R01_ _	Danger – Rotating fan blades! Fans may start automatically at any time. Make sure that the auxiliary voltage is switched off and locked before removing the casing
2*	3BHB017203R02_ _	Notice – Maximum angle between lifting cables must be less than 30°
3	3BHB017191R02_ _	Danger – Hazardous voltage inside. Disconnect power and ground equipment before removing this cover
4	3BHB017208R05_ _	Caution – Burn hazard. Components may be very hot

* One label on each side of the drive.

Safety signs

Depending on the delivery, the following additional safety signs may be provided:

Fire fighting

This sign explains the procedure for fighting fire in electrical equipment. The sign should be installed in an easily-seen location near the drive.



Dimensions:
50 x 30 mm [2 x 1.2 in]

—
07

Heart pacemaker

The magnetic field of the drive can influence the functioning of heart pacemakers. The sign should be installed at the entrance to the drive room or at a minimum distance of 6 meters [20 ft] from the drive!



Diameter: 32 cm [12.5 in]

—
08

Potential equipment hazards

When the drive is powered up, hazardous voltages are present inside the cabinet.

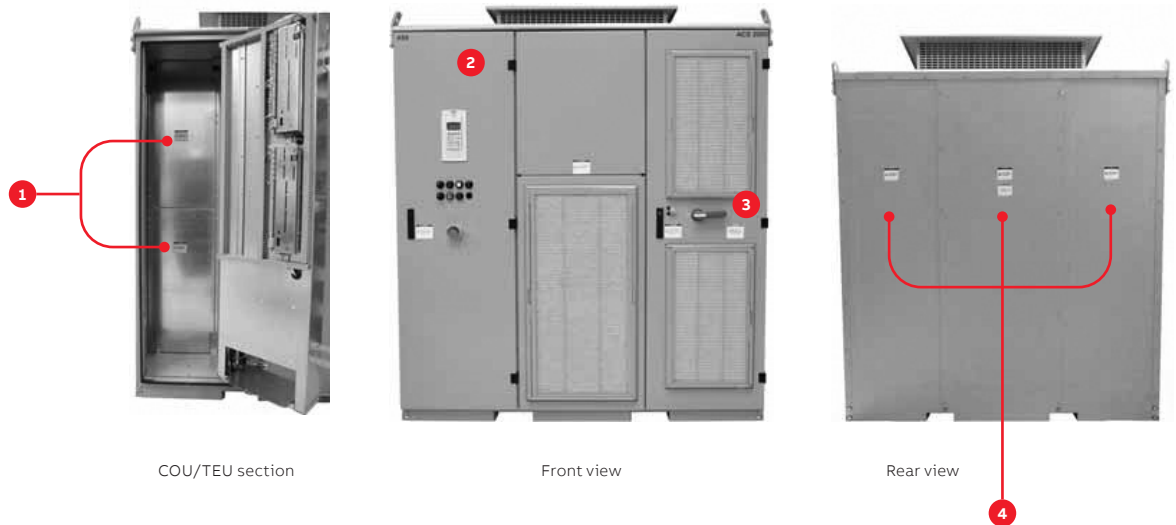

1	Inside covers of Terminal Entry Unit (TEU)
2	Locked door of low voltage CONTROL Unit (COU)
3	Locked AFE/INU compartment door with Kirk® key mechanical interlock and grounding switch
4	Outside covers

Potential equipment hazard locations

To maintain safety and minimize hazards, strictly observe the following:

- Do not open the AFE/INU compartment door (3) or remove an outside wall or a cover (4), as long as the drive is energized
- Do not remove any of the covers (1) inside the cabinet when the drive is energized
- Do not energize the equipment before all internal covers (1) have been securely fastened
- Components inside the cabinet may be hot after the drive has been in operation. Before opening a cover or door, wait until the fan has stopped
- Use approved grounding practices when working on the drive

Safety measures

To maintain safety when the equipment is powered up, the door of the AFE/INU compartment (see 3 in Figure 10) is secured by two safety measures. Frame 3 drives also include a third safety measure, the door interlocking mechanism. The door will not open unless these safety steps are completed.

The grounding switch must be moved to the grounded position, which can only be done after the DC link capacitors have been discharged.

See section Doors and door locks for further information.

Frame 1

The Kirk key mechanical interlock allows access to the AFE/INU door only after the main power has been switched off and the ground switch is moved to the grounded position.

Frame 2

The Kirk key mechanical interlock allows access to the filter compartment door only after the main power has been switched off and the ground switch is moved to the grounded position. Once this door has been opened, the AFE/INU door can be opened by releasing the top and bottom draw latches located inside the door.

Frame 3

The Kirk key mechanical interlock allows access to the filter compartment door only after the main power has been switched off and the ground switch is moved to the grounded position. Once this door has been opened, the left AFE/INU door can be opened. After opening this door, the right AFE/INU door can be opened by releasing the top and bottom draw latches located inside the door.

—
10
AFE/INU door
safety measures

A spring-loaded rotating bar with door stops, located just inside the AFE/INU doors at the bottom of the cabinet, provides interlocking between filter compartment door and converter doors, requiring the doors to be closed in the reverse order. The right AFE/INU door must be closed and latched, followed by the left AFE/INU door and, finally, the filter compartment door.



DANGER: Hazardous voltage!

All doors must be closed and secured to prevent unintentional contact with energized components.

- Check the interlocking mechanism is operable before turning the drive on. Repair or replace the interlocking mechanism if it is damaged
- Use care when servicing the drive, being careful not to step on the interlocking mechanism. Excessive pressure could cause the bar to bend
- Do not disable this safety feature

Light pressure needs to be applied to the bottom of the door during the closing of each door in order to force the spring-loaded bar to rotate.

NOTICE

NOTICE: Do not use excessive pressure to bottom of door during closing. Excessive force may cause damage to the drive.

The final (left-most) door must be closed before the drive becomes operational. Once all doors are closed, the Kirk key and ground switch can be operated.



See Appendix I - Kirk Key Specifications, located on the CD, for detailed information.



1	Grounding switch (grounded position)
2	Kirk key
3	AFE/INU compartment door

—
11
Frame 3 AFE/INU
door additional
safety measure

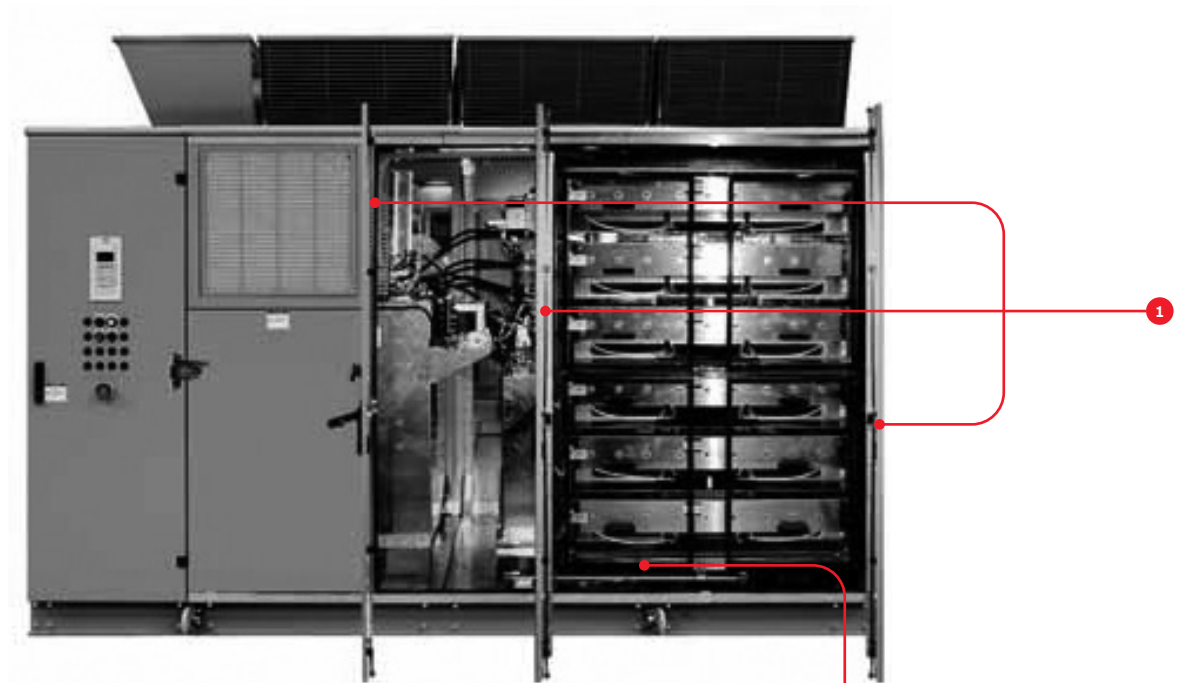

1	Access doors
2	Rotating bar
3	Spring-loaded mechanism



Power electronics and cabinet features

The ACS2000 is an air-cooled, general purpose variable frequency drive for the control of standard induction motors with 4 kV voltage.

—
12
ACS2000
—
13
ACS2000 Drive
system overview

Overview

Due to the multi-level topology of the power electronic components, the drive produces nearly sinusoidal current and voltage waveforms at its output terminals, making it suitable for standard input transformers and induction motors.

The following sections provide an overview of the available auxiliary and main power configurations and introduce the power electronic components of the drive. The cooling system and cabinet features such as the grounding switch and the door interlock are also described.



Drive topology

Topology

This section describes the main design features and introduces the major power electronic components of a typical ACS2000 drive.



If you have ACS2000 with the integral input contactor disconnect option, refer to Appendix P, section Electrical installation, for topology information.

—
12

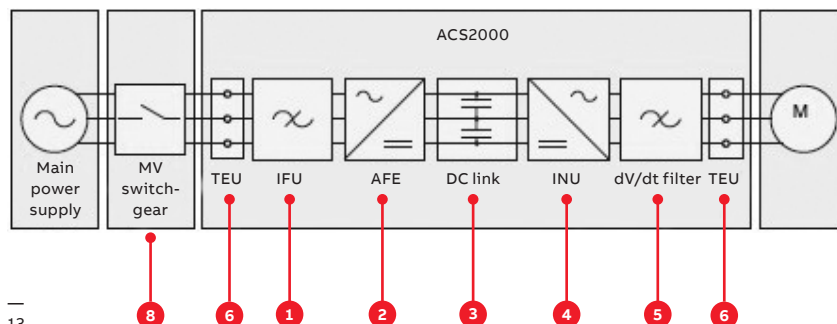

—
13

14
Frame 1 overview

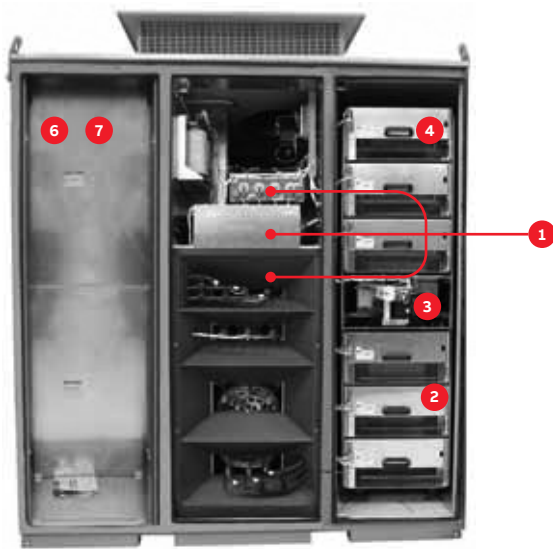

Cabinet front

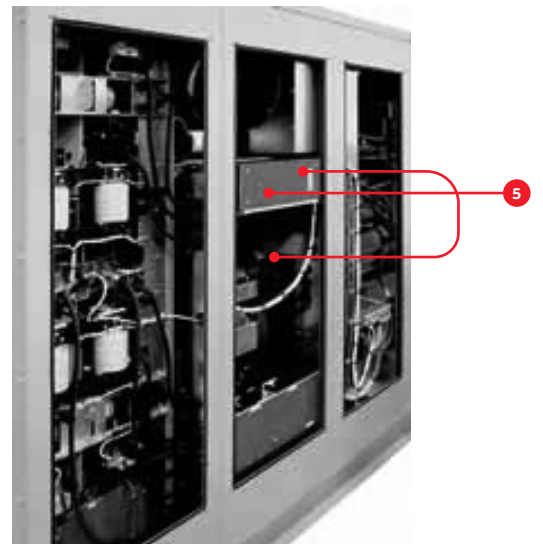

Cabinet rear

1	IFU - Input Filter Unit
2	AFE - Active Front End
3	DC link
4	INU - INverter Unit
5	dV/dt filter
6	TEU - Terminal Entry Unit for line and motor cables (behind access panels)
7	Removable access panels for entry to TEU
8	Customer supplied isolating means – typically a fused input contactor with visible blade disconnect



See Section Isolating means (MV Switchgear) and Appendix G - MV switchgear guide, located on the CD, for additional information.

—
15
Frame 2 overview

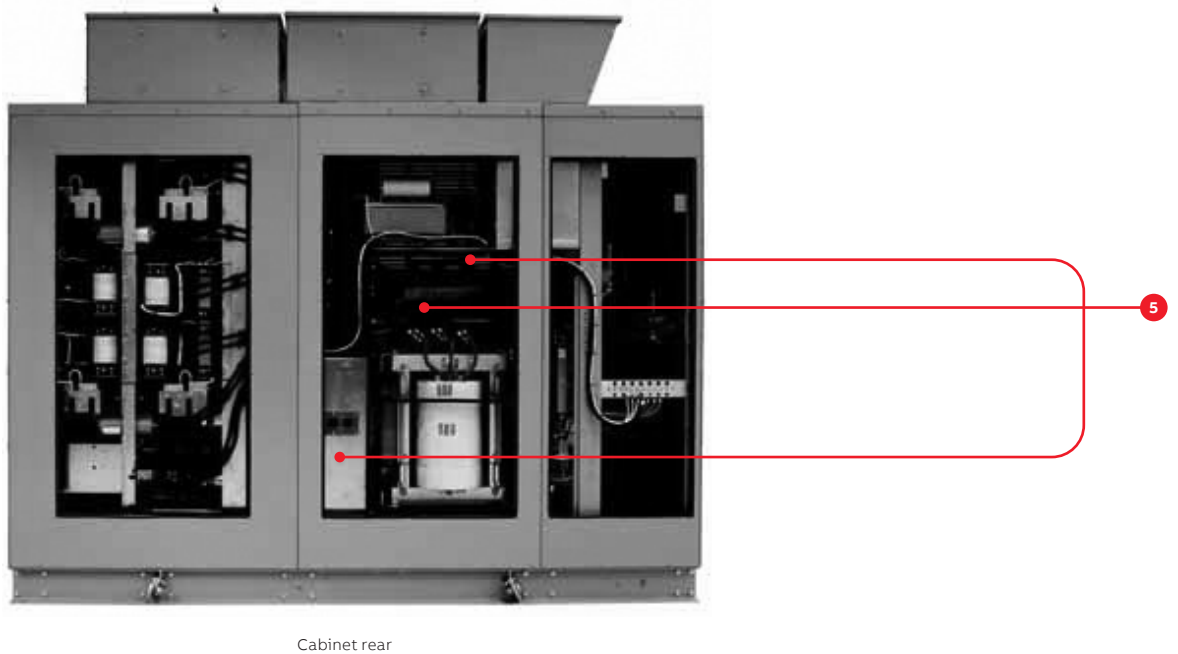
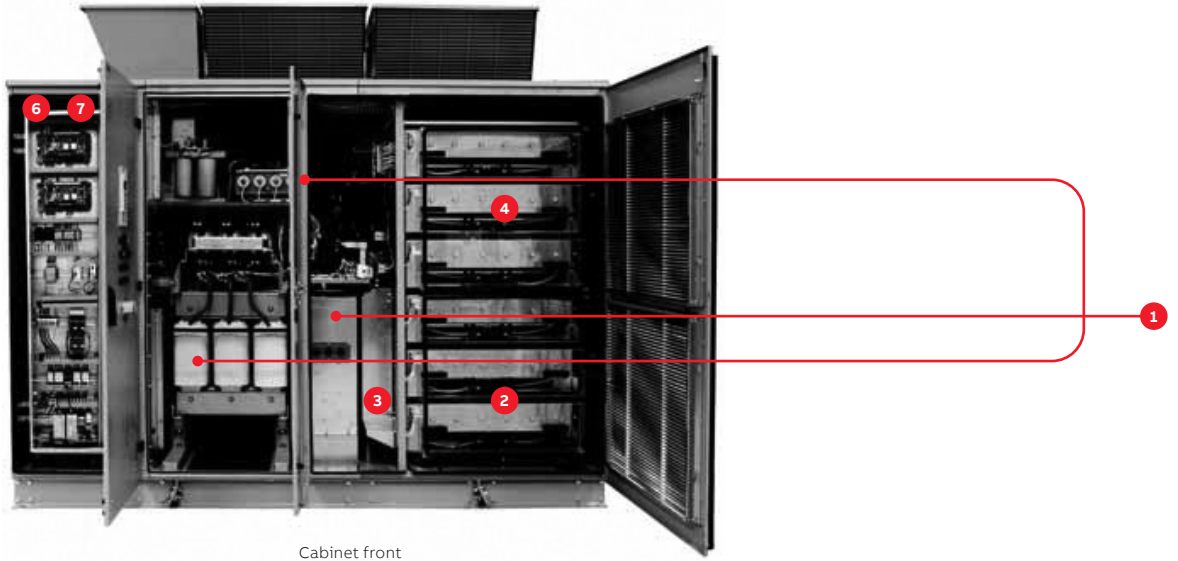

1	IFU - Input Filter Unit
2	AFE - Active Front End
3	DC link
4	INU - INverter Unit
5	dV/dt filter
6	TEU - Terminal Entry Unit for line and motor cables (behind access panels)
7	Removable access panels for entry to TEU
8	Customer supplied isolating means – typically a fused input contactor with visible blade disconnect



See Section Isolating means (MV Switchgear) and Appendix G - MV switchgear guide, located on the CD, for additional information.

16
Frame 3 overview

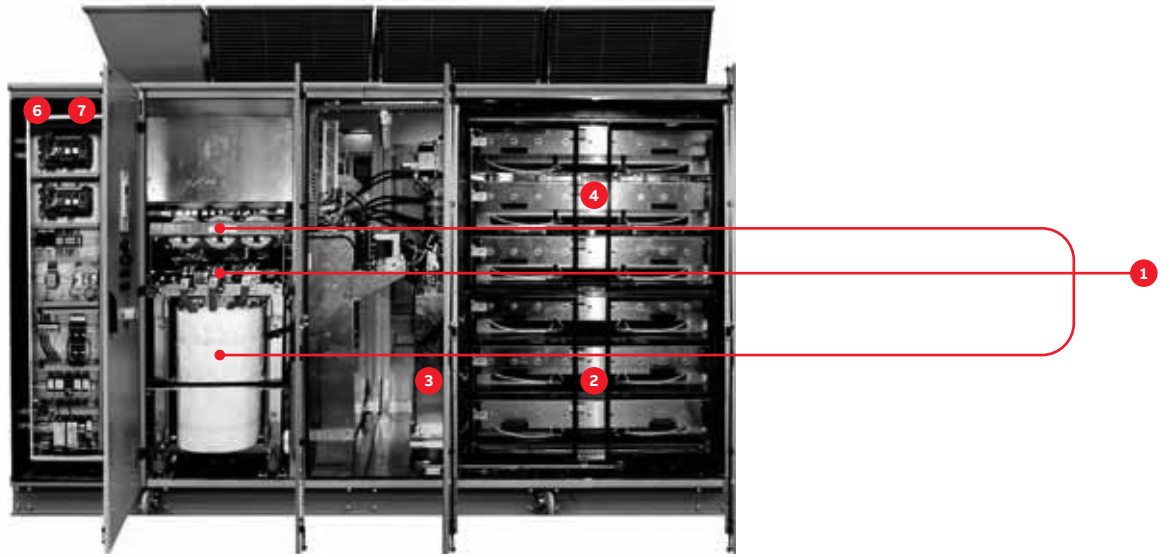

Cabinet front

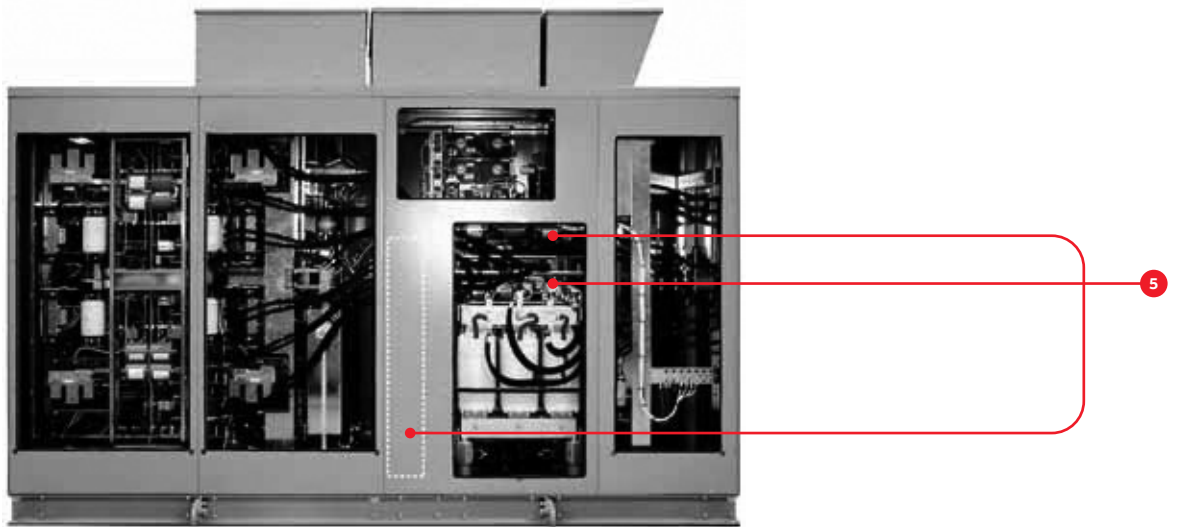

Cabinet rear

1	IFU - Input Filter Unit
2	AFE - Active Front End
3	DC link
4	INU - INverter Unit
5	dV/dt filter
6	TEU - Terminal Entry Unit for line and motor cables (behind access panels)
7	Removable access panels for entry to TEU
8	Customer supplied isolating means – typically a fused input contactor with visible blade disconnect



See Section Isolating means (MV Switchgear) and Appendix G - MV switchgear guide, located on the CD, for additional information.

—
17
IFU input filter
—
18
Energy flow in
ACS2000 AFE Drive

IFU - Input Filter Unit

Refer to Figure 17. The IFU is located between the source and the AFE. The IFU is a tuned filter: inductors (1), resistors (2), and capacitors (3) that reduce harmonic disturbances injected to the supply network.

1	Inductors
2	Resistors
3	Capacitors

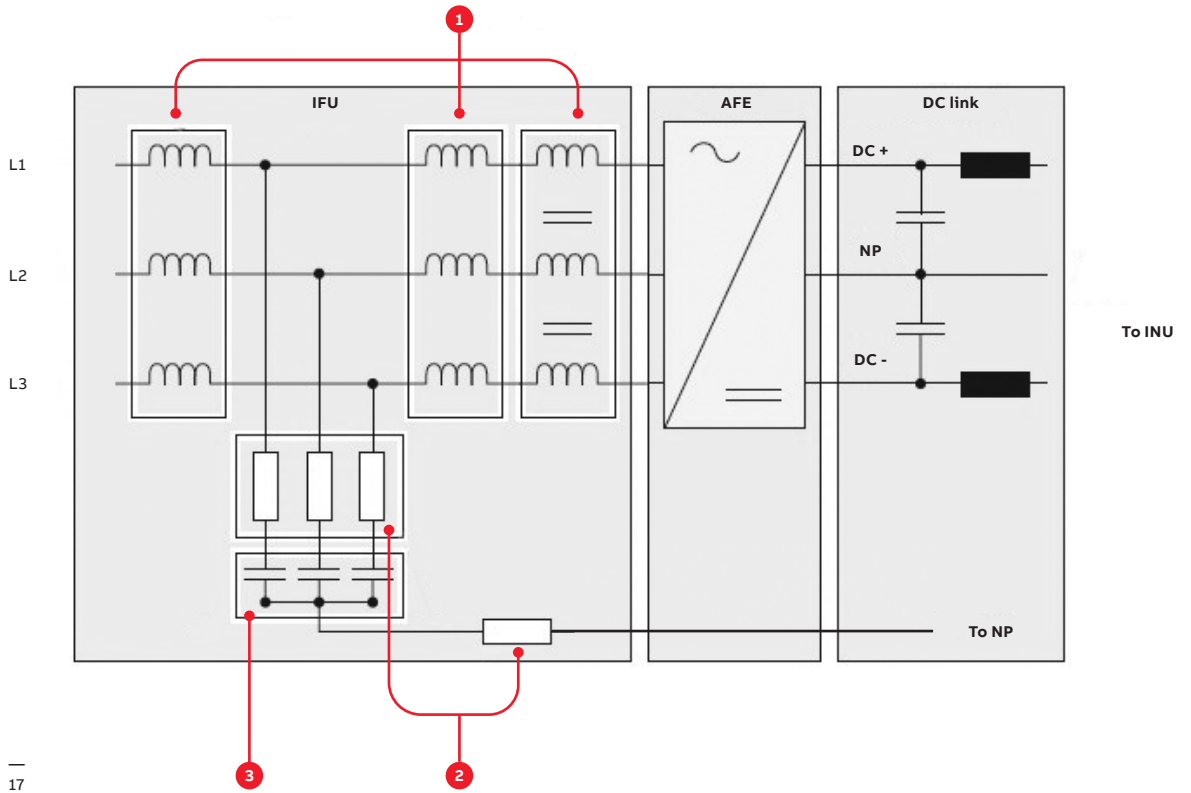

AFE - Active Front End

The front end of the drive consists of an active rectifier for regenerative operation. The AFE features the same electrical design as the INU (INverter Unit) of the drive.

The AFE rectifies the AC line voltage of the supply network and connects its output to the DC link. The AFE maintains the DC link voltage at the required level and provides unity power factor at the input terminals of the drive.

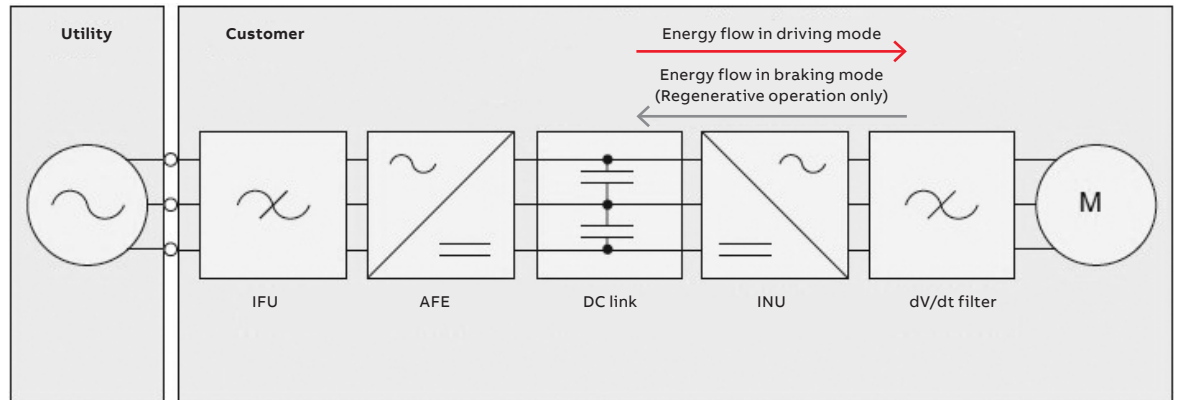

—
19
AFE compartment

—
20
Phase module



1	L1 phase module of AFE
2	L2 phase module of AFE
3	L3 phase module of AFE
4	Extracted phase module
5	AFE compartment
6	Air plenum



—
19

Phase module

The AFE consists of three identical phase modules, each housing the HV IGBT (Insulated Gate Bipolar Transistor) semiconductors, phase capacitors, gate drivers and the interface board for communication with the circuit board of the AFE (AMC circuit board).

The high voltage IGBT is a power semiconductor switching device specially developed for medium voltage drives. The device combines high speed switching capabilities with high blocking voltage and low conduction losses. The phase modules can be removed from the cabinet for maintenance and service.

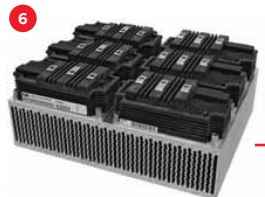
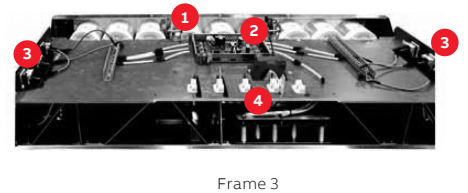
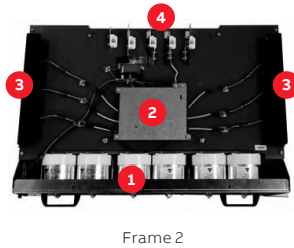
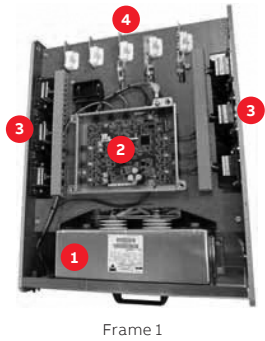

1	Phase capacitor
2	Phase INT board
3	Gate drivers
4	Medium voltage connectors
5	IGBT module
6	IGBT assembly on heat sink

—
20

—
21
DC link capacitor

DC link

The DC link consists of the capacitor, the charging unit and the grounding switch. The capacitor is oil-filled and features self-healing technology.

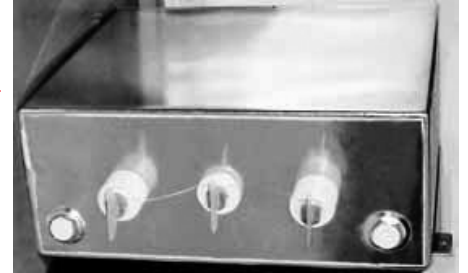

1 DC link capacitor

Charging unit

The charging unit consists of the charging transformer and low and high voltage relays.

Charging

The charging unit is fed from the auxiliary power supply and charges the DC link and the phase capacitors.

The unit charges the DC link capacitor and the phase capacitors before the MV (Medium Voltage) switchgear is closed to connect the drive to the main power supply. This eliminates excessive inrush current when connecting to the MV supply.

The charging sequence is started by pressing the SUPPLY ON pushbutton on the control compartment door. After the charging sequence has finished, the charging unit is disconnected from the medium voltage circuit, the MV switchgear is closed and the DC link will reach its nominal level.

Typical time from pressing the SUPPLY ON pushbutton to completion of the pre-charge sequence is approximately 10 seconds for Frame 1 (see Table 4).

Discharging

Discharging is initiated by pressing the SUPPLY OFF pushbutton on the control compartment door, which opens the MV switchgear. The DC link capacitors will then discharge via active modulation. The energy stored in the capacitors is dissipated in the clamping resistors of the power part of the drive. When the DC link voltage has decreased below 25% of its nominal value, the capacitor in the phase modules begin to discharge.

Stand-by mode

Once the DC link is charged, it is possible to keep the drive in this state to facilitate a more rapid start-up procedure. The losses during stand-by mode are approximately 1% of the nominal power and are caused from small losses from the AFE, the INU and the auxiliaries.

—
22
Grounding switch

Grounding switch

The grounding switch is a safety device that enables safe access to the AFE / INU compartment of the drive.

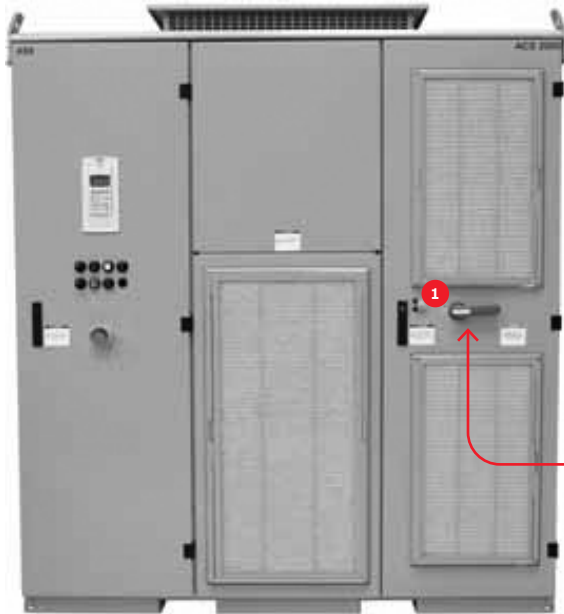

Frame 1

Typical Frames 2, 3 (Frame 2 pictured)

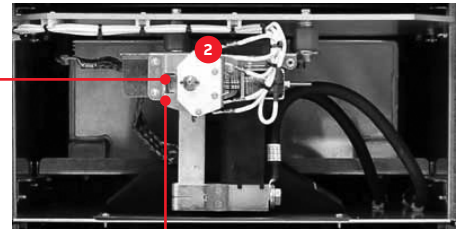

- | | |
|---|------------------------------------------------------|
| 1 | Grounding switch handle (Shown in grounded position) |
| 2 | Grounding switch - detailed interior view |

When the switch is in the grounded position, the input filter, AFE, DC link, INU and dV/dt output filter of the drive are connected to the PE (protective earth) ground, provided none of the phase modules is extracted from the cabinet. Refer to Figure 23.

—
23
Grounding circuit

—
24
Grounding the drive

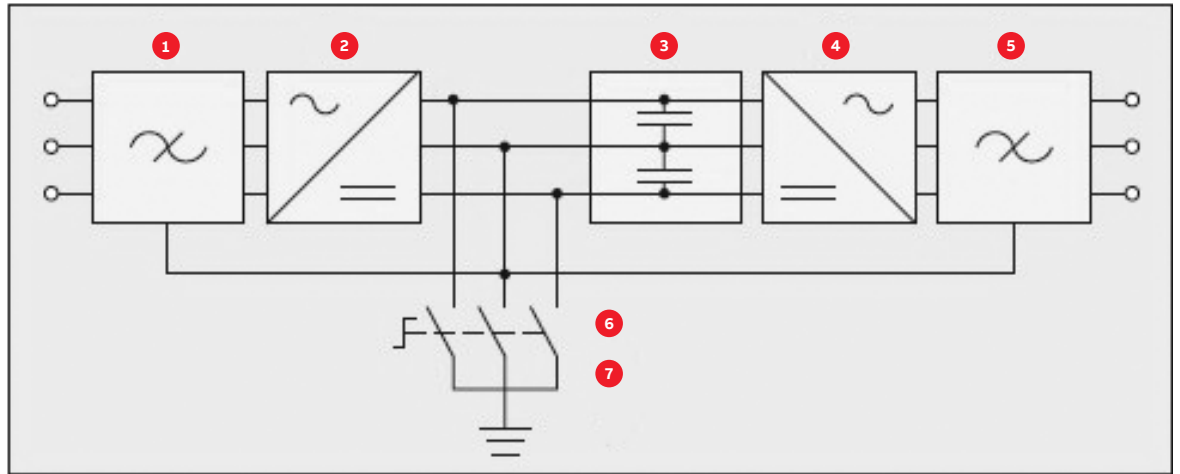

1	Input filter
2	AFE - Active Front End
3	DC link
4	INU - INverter Unit
5	dV/dt output filter
6	Grounding switch
7	PE ground

—
23

The switch is electromechanically interlocked with a discharge monitoring circuit to prevent closing of the switch while the DC link capacitor is still charged.

Grounding the drive is only possible after the main power supply has been disconnected and the DC link has discharged. The DC link is considered discharged when the voltage level is below 50 VDC. At this voltage level, the “GROUND SW RELEASED” pilot light (see 1, in Figure 24) on the door of the control compartment will light up, indicating that the grounding switch can be turned to the grounded (O) position (see 2, in Figure 24).

When the grounding switch is in the grounded position (see 2, in Figure 24), the Kirk® key and the MV compartment door key (triangular) are used to open the AFE/INU compartment door.



See Appendix P - Integral Input Contactor Disconnect, located on the CD, for detailed information on drives with this option.

It is not required to disconnect the main power supply before grounding the drive via the ground switch; with the integral input contactor disconnect and auxiliary drive transformer option the proper procedure is to let the drive discharge, operate the ground switch, and then open the isolation switch.

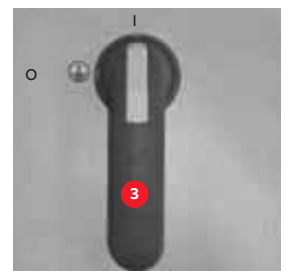
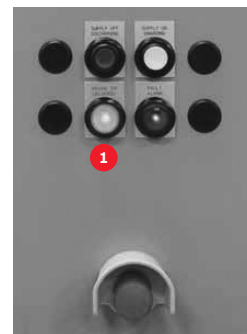

1	GROUND SW RELEASED pilot light
2	Grounding switch handle - grounded (OFF) position
3	Grounding switch handle - ungrounded (ON) position

—
24

—
25
INU - INverter Unit
multi-level topology
and waveform

INU - INverter Unit

The INU converts the DC voltage to the required AC motor voltage and frequency.

Like the AFE, the INU is an active 3-phase unit with the same electrical configuration. The unit is designed as a self-commutated, 5-level voltage source inverter.

As a result of the multi-level topology, the drive produces nine switching levels, phase to phase. The resulting waveforms permit the application of standard induction motors.

The INU is composed of three identical phase modules (see section Phase module). The phase modules can be removed from the cabinet for maintenance and service.

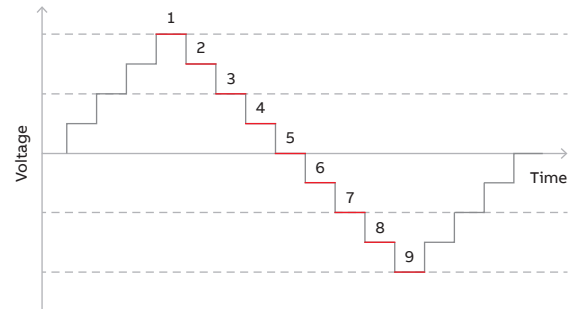

—
25

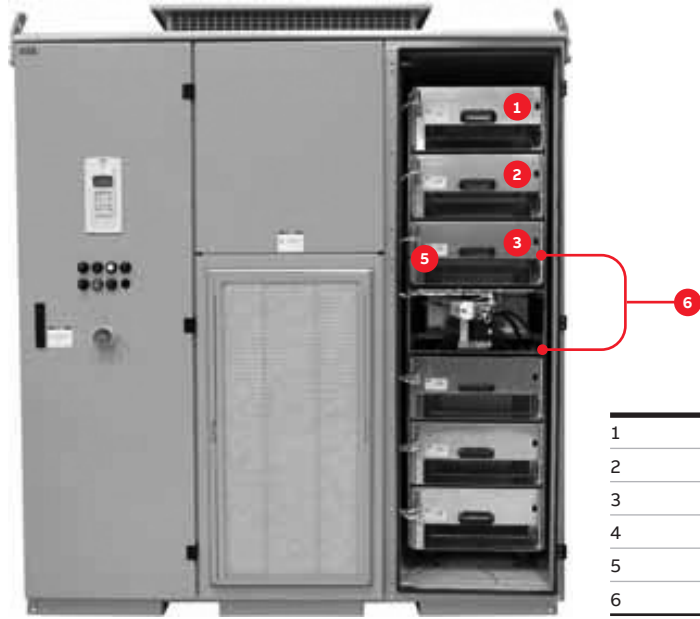
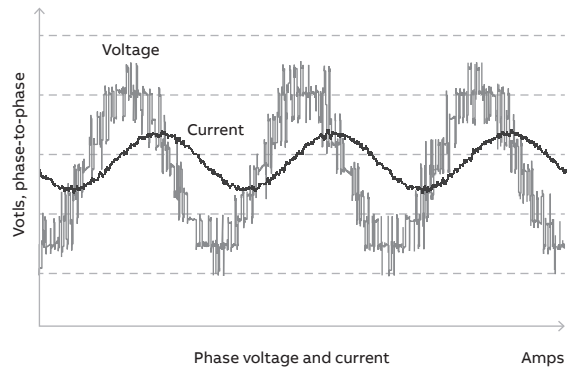

1	U2 phase module of INU
2	V2 phase module of INU
3	W2 phase module of INU
4	Extracted phase module
5	INU compartment
6	Air plenum

—
26

—
27
dV/dt filter schematic

—
28
Frame 1 dV/dt filter
(rear view shown)

—
29
Frame 2 dV/dt filter
(front view shown)

—
30
Frame 3 dV/dt filter
(rear view shown)

dV/dt filter

Refer to Figures 27 and 28. The INU includes a 3-phase dV/dt filter connected to its AC output. The filter protects the motor against excessive voltage rate of rise. The filter components are: inductors (1), resistors (2), and capacitors (3).

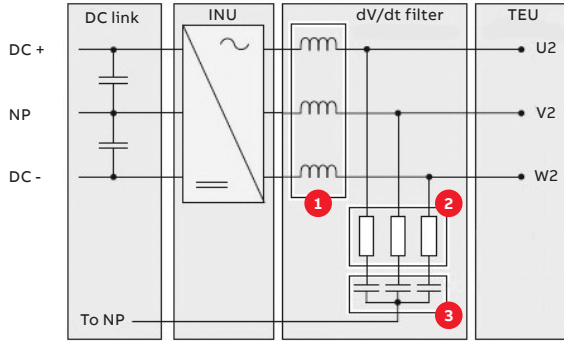

- 1 Inductor
- 2 Resistors
- 3 Capacitors

—
27

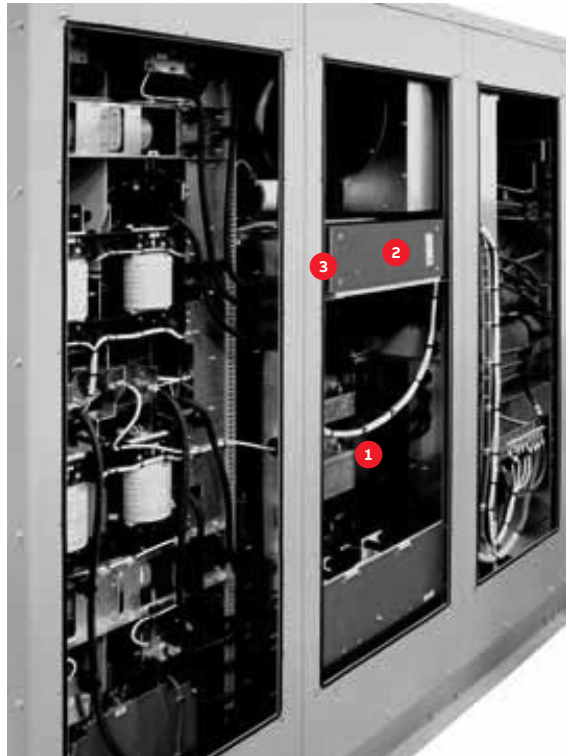

- 1 Inductor
- 2 Resistors
- 3 Capacitors

—
28



- 1 Inductor
- 2 Resistors
- 3 Capacitors

—
29

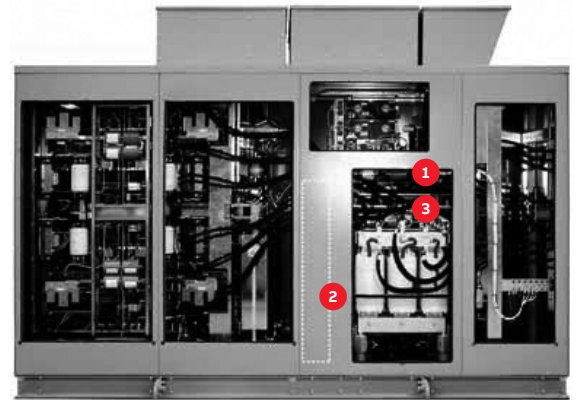

- 1 Inductor
- 2 Resistors
- 3 Capacitors

—
30

Doors and door locks

To ensure safety and to prevent the doors from being opened unintentionally, both doors are lockable, and the AFE/INU compartment door where medium voltage is present during operation is mechanically interlocked. The door locks also have inserts to ensure that these doors can only be opened by personnel authorized to do so.

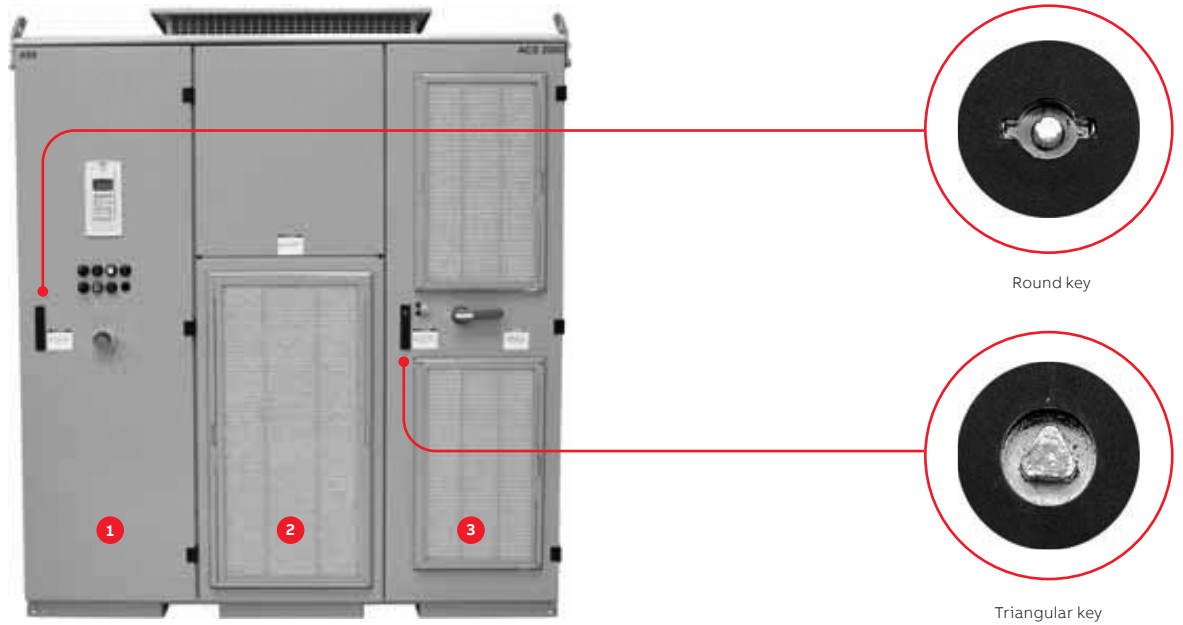

	Door of control compartment with swing frame: lockable
1	Cover plates behind the control compartment for power terminal entry unit access: bolted
	Cover of input filter compartment: bolted
2	The ventilation grill can be removed during operation to replace the filter mat
	Door of AFE/INU compartment: Mechanically interlocked and lockable
	Door cannot be opened when the main power has been applied
	Door cannot be opened when the drive is ungrounded
3	The ventilation grills can be removed during operation to replace the filter mat

Door safety interlocking

Function

There are two safety features in place on the AFE/INU compartment door that prevent unsafe conditions:

- The interlocking system ensures that the MV switchgear cannot be closed and the main power cannot be supplied to the drive unless the door is securely closed and the grounding switch is in position not grounded
- The interlocking system also ensures that the door cannot be opened until the main power is disconnected, the DC link capacitors are discharged and the grounding switch is in position grounded

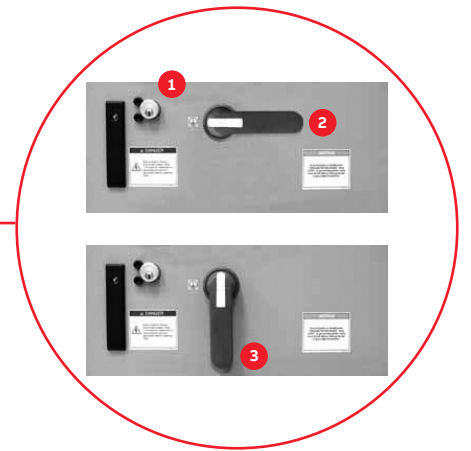

1	Kirk key
2	Grounding switch (shown in grounded position)
3	Grounding switch (shown in ungrounded position)

Kirk key interlock

The Kirk key system is mechanically interlocked to the upstream disconnect using one master key and two locks. The key must be in place in the upstream disconnect in order for the drive to be energized.

Follow local lock-out, tag-out safety procedures.



See Appendix I - Kirk Key Specifications, located on the CD, for detailed information.

See Appendix P - Integral Input Contactor Disconnect, located on the CD, for detailed information on drives with this option.

The upstream disconnect may be the integral input contactor disconnect option.

Frame 3 drives also incorporate a third safety feature, the door interlocking mechanism, to ensure that the three access doors are closed.

The door of the control compartment is not integrated into the interlocking system and can always be opened.



WARNING: Dangerous voltage is present. Grounding the drive does not switch off control voltage from a separate source. Auxiliary power supply will remain live.

The Kirk key for this option is located behind the door of the disconnect section.

Grounding switch

The grounding switch will only allow the capacitors to be charged when the switch is in the ungrounded position.

Door interlocking mechanism, Frame 3 only

The door interlocking mechanism is a spring loaded rotating bar with door stops located just inside the MCB and AFE/INU doors at the bottom of the Frame 3 drive cabinet, which ensures that the doors allowing access to medium voltage equipment are closed before the drive is operational. Once all doors are secured, the Kirk key and ground switch can be operated as indicated in sections Kirk key interlock and Grounding switch.

Power supply configurations

The drive requires two independent power supplies:

- Auxiliary power supply (eg. 480 V) for the control and cooling equipment

See Appendix P - Integral Input Contactor Disconnect, located on the CD, for detailed information on drives with this option.

The upstream disconnect may be the integral input contactor disconnect option. The Kirk key for this option is located behind the door of the disconnect section.

Note: Auxiliary power may be provided by the integral input contactor disconnect on drives with this option.

- Main power supply (eg. 4160 V) for the power electronic components

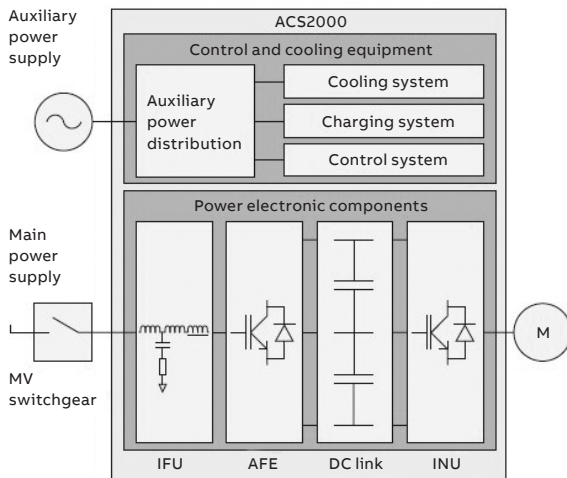

Auxiliary power supply

The ACS2000 drive system requires an auxiliary power supply to provide power for the internal controls, pre-charge system, and fan(s). This power is supplied via a 3-phase 480 V power feed (400 V and 600 V auxiliary supply voltages are available by option). In the event of power interruption, the internal controls power supplies are buffered to ride through for 0.2 seconds. If power is not restored, the drive will perform a controlled shutdown and indicate fault.

The power draw of the drive is shown in Table 4. The auxiliary supply is wired to terminal block X01 (see Figure 34).

i See Appendix P - Integral Input Contactor Disconnect, located on the CD, for detailed information on drives with this option.

The upstream disconnect may be the integral input contactor disconnect option. The Kirk key for this option is located behind the door of the disconnect section.

Note: Auxiliary power may be provided by the integral input contactor disconnect on drives with this option.

Note: The power feed for the auxiliary supply shall be protected with suitable branch circuit protection rated according to Table 4.

i See Appendix E - Wiring diagrams, located on the CD, for information on the configuration of the auxiliary power interface present in the drive.

See Rating label of the drive located on the back of the control compartment door for information on the rated voltage(s) and current(s) that the auxiliary power must match. See Chapter Control system, Figure 34 for terminal block location.

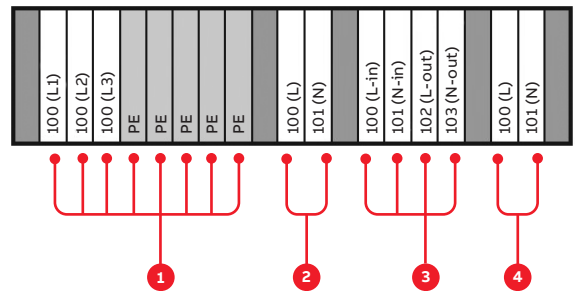

1	Terminal Block X01: Three-phase auxiliary power supply
2	Terminal Block X02: Single-phase control power supply (option)
3	Terminal Block X19: Motor space heater protection (option)
4	Terminal Block X20: Converter space heater power supply (option)

Table 4: Current consumption during precharge and auxiliary power supply requirement

Auxiliary power supply voltage	Current consumption during precharge (A)	Precharge time (s)	System current (A)	Power requirement (kVA)
Frame 1				
480 V	21	8	8	6
400 V (option)	25	11	9	6
600 V (option)	17	8	6	6
Frame 2				
480 V	28	18	14	11
400 V (option)	33	24	16	11
600 V (option)	22	18	11	11
Frame 3				
480 V	33	27	21	17
400 V (option)	40	39	25	17
600 V (option)	27	27	17	17

Single-phase control power (option)

The control system can be supplied via a single-phase power supply. See Table 5 for the phase voltage and normal running current of the drive. This option has the advantage that the main control hardware will remain energized and the full ride-through capabilities of the drive can be used. In the event of a 480 V auxiliary power outage, communication to a higher-level control system will not be lost. This control supply is wired to terminal block X02. See Figure 34.

Table 5: Single-phase power supply requirement

Single-phase supply voltage	Current (A)*		
	Frame 1	Frame 2	Frame 3
120 V	5	5	10
230 V	3	3	6

* Depending on option configuration, the actual current consumption may be lower.

Internal control UPS (option)

A battery-based UPS (Uninterruptible Power Supply) is available as an option, increasing the control buffer time to 15 minutes after loss of control power. In the event of a control power outage, communication to a higher-level control system will not be lost.

Monitoring of battery health is provided. The battery is located at the bottom of the swing frame to allow for easy replacement.

To prolong battery life when drive control power is shut down, switch the battery control module to the “service” setting. When control power is restored, the battery control module should be switched back to the “12A-h” setting.

Converter space heater (option)

When the converter space heater is installed on the drive, an additional 120 V power supply cable is required. This control supply is wired to terminal block X20 as illustrated in Figure 34.

Table 6: Space heater power supply requirement

Single-phase supply voltage	Current (A)*		
	Frame 1	Frame 2	Frame 3
120 V	7	7	7
230 V	4	4	4

Motor space heater protection (option)

This option provides a circuit breaker with trip monitoring and a contactor for a motor space heater that is provided by the customer. An additional 120 V power supply cable is required.

Motor space heater currents of up to 5 A continuous are supported.

Main power supply configuration

The ACS2000 4 kV drive includes an input filter unit which enables the drive to be connected directly to the 4160 V main power supply as shown in Figure 35. For drives with the integral input contactor disconnect, the power fuses are relocated to the switchgear, see Appendix P for details.



See Appendix P - Integral Input Contactor Disconnect, located on the CD, for main power supply configuration and details on the TEU when the drive is ordered with this option.

—
35
Single-line diagram
with direct-to-line
configuration

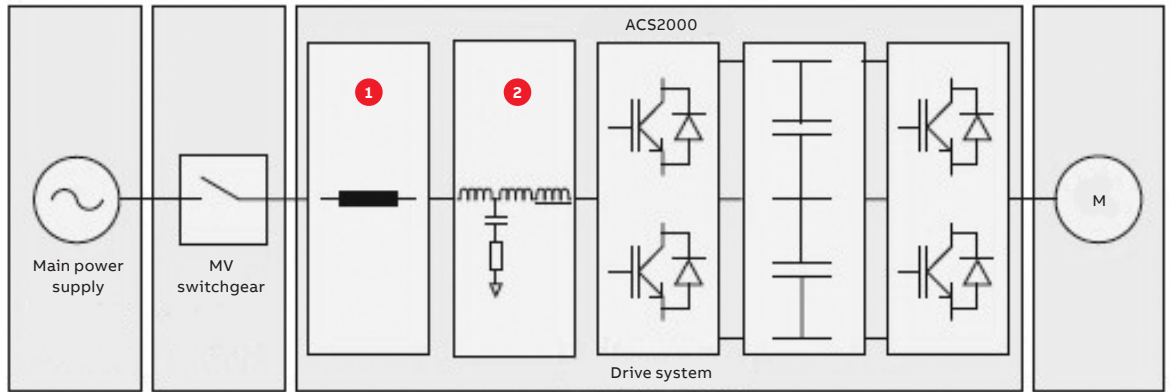

- | | |
|---|-------------------|
| 1 | Fuse |
| 2 | Input filter unit |

Power fuses

There are three semiconductor rated power fuses located in the TEU for the purpose of providing input protection for the drive.



Note: On drives with the integral input contactor disconnect option, the fuses are located in the disconnect cabinet.

—
Table 7: Power fuse ratings

Drive rating kW [hp]	Current rating (A)	ABB part number	Quantity per phase
Frame 1			
224-298 [300-400]	80	2UEA001267	1
336-522 [450-700]	140	2UEA001268	1
597-746 [800-1000]	200	2UEA000093	1
Frame 2			
933 [1250]	140	2UEA001268	2
1119-1492 [1500-2000]	160	2UEA002203	2
Frame 3			
1679-2238 [2250-3000]	230	2UEA001947	2

—
36
Terminal entry unit

TEU - Terminal Entry Unit

The terminal entry unit provides the terminals for the line supply (power in) and motor cables and the ground bus for the termination of the ground cable and the cable shields.

The cables enter through the top or through the floor of the cabinet: the ACS2000 drive supports either method.

The ground bus slotted hole feature supports both NEMA and IEC lugs.

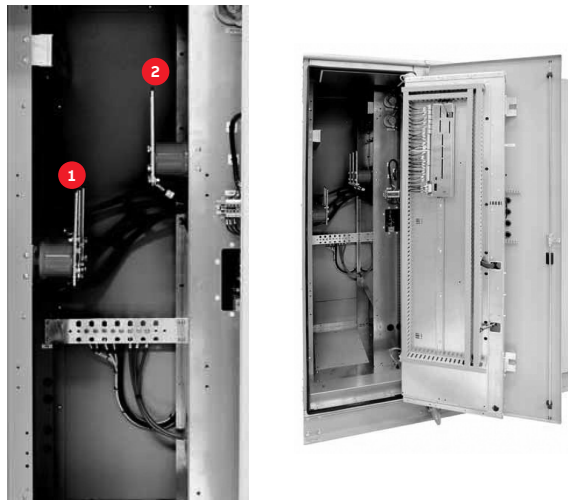

1	Motor OUT terminals (U2, V2, W2)
2	Power IN terminals (L1, L2, L3)

—
36

Cooling

The air cooling unit feeds air to the main power electronic components to transfer heat out of the cabinet. The standard cooling fan is a 3.8 kW unit with the following performance characteristics:

- Power: 3.8 kW
- Airflow capacity: 8500 m3/h [5000 cfm]
- Pressure: 600 Pa [2.4 in. H2O]
- Speed: 1280 rpm

An optional redundant fan can be installed on top of the drive.

Table 8: Fan location and quantity

	Location	Frame 1	Frame 2	Frame 3
Standard fan(s)	Internal	1	1	1
	External	0	1	2
Number of redundant fans	External	1	1	1

Function

The fan unit is switched on by the control system of the drive when the DC link is charged.

The fan runs continuously for a preset time after the main power has been switched off to circulate air that cools the drive components.

Air enters the front of the cabinet through ventilation grills, passes through the compartments and exits via the fan out the top of the drive.

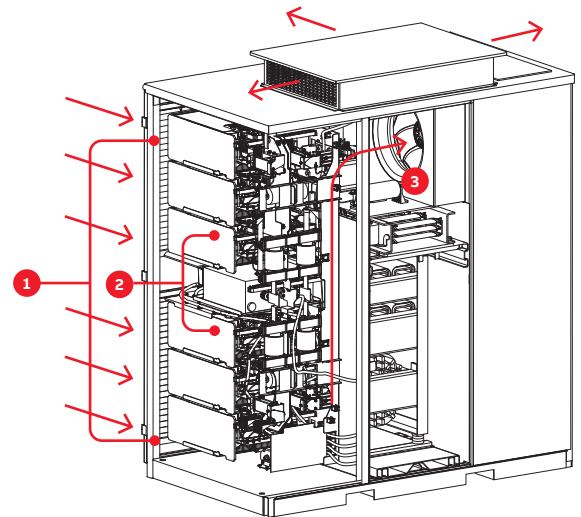

1	Ventilation grills
2	Phase modules
3	Fan

—
37

Circulating air cools the AFE/INU components (see Figure 37) as it enters through the ventilation grills (1), flows across each of the six phase modules (2), travels along the rear wall of the compartment to an access hole and exits to the fan (3).

The airflow across the phase modules is monitored by an air pressure switch. If the filter mats are clogged and the pressure drop reaches the specified final pressure loss, the message **Conv1CoolAirFilter** is displayed on the CDP control panel and the alarm/fault pilot light on the control compartment door illuminates.

—
38
Frame 1 Airflow - filter
compartment (cross-
section rear view)

—
39
Frames 2, 3 Airflow - filter
compartment (cross-
section rear view)

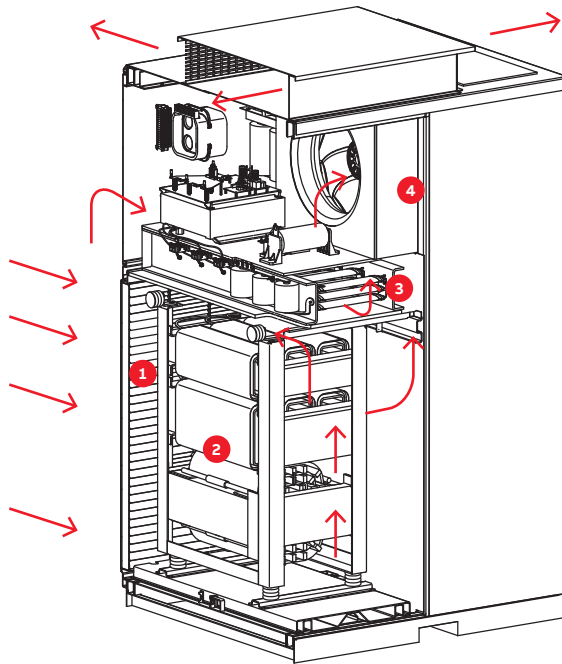

1	Ventilation grills
2	IFU inductors
3	Filter resistors
4	Fan

—
38

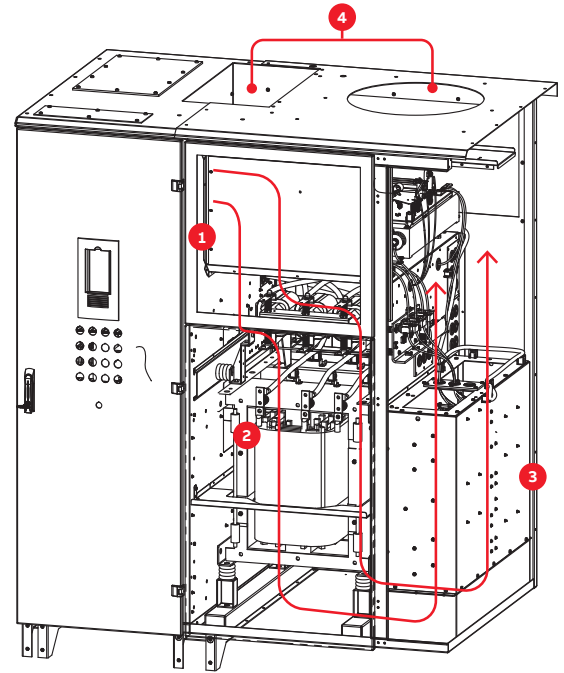

1	Inlet grill
2	IFU inductors
3	Filter resistors
4	Air outlets (fans)

—
39

The filter compartment (see Figure 38 - Frame 1, Figure 39 - Frames 2, 3) is cooled by air that enters through the ventilation grill (1), passes the IFU inductors (2), circulates up through access holes to the filter resistors(3), and exits to the fan (4).

Cabinet design

Heavy-duty 2.5 mm [12 gauge] external panels with integral frame structure incorporate cabinet strength and stability.

Control system

—
40
Control compartment
exterior

LV control compartment

The LV (Low Voltage) control compartment incorporates the hardware for control, monitoring and protection functions of the drive and the communication interfaces with the local control panel and with external control devices.

The control compartment door can be opened to access the circuit boards. The swing frame can be opened for further access to the drive components: customer I/O connections and terminal blocks, etc.



1 Local operator control panel

—
41
Control compartment
interior

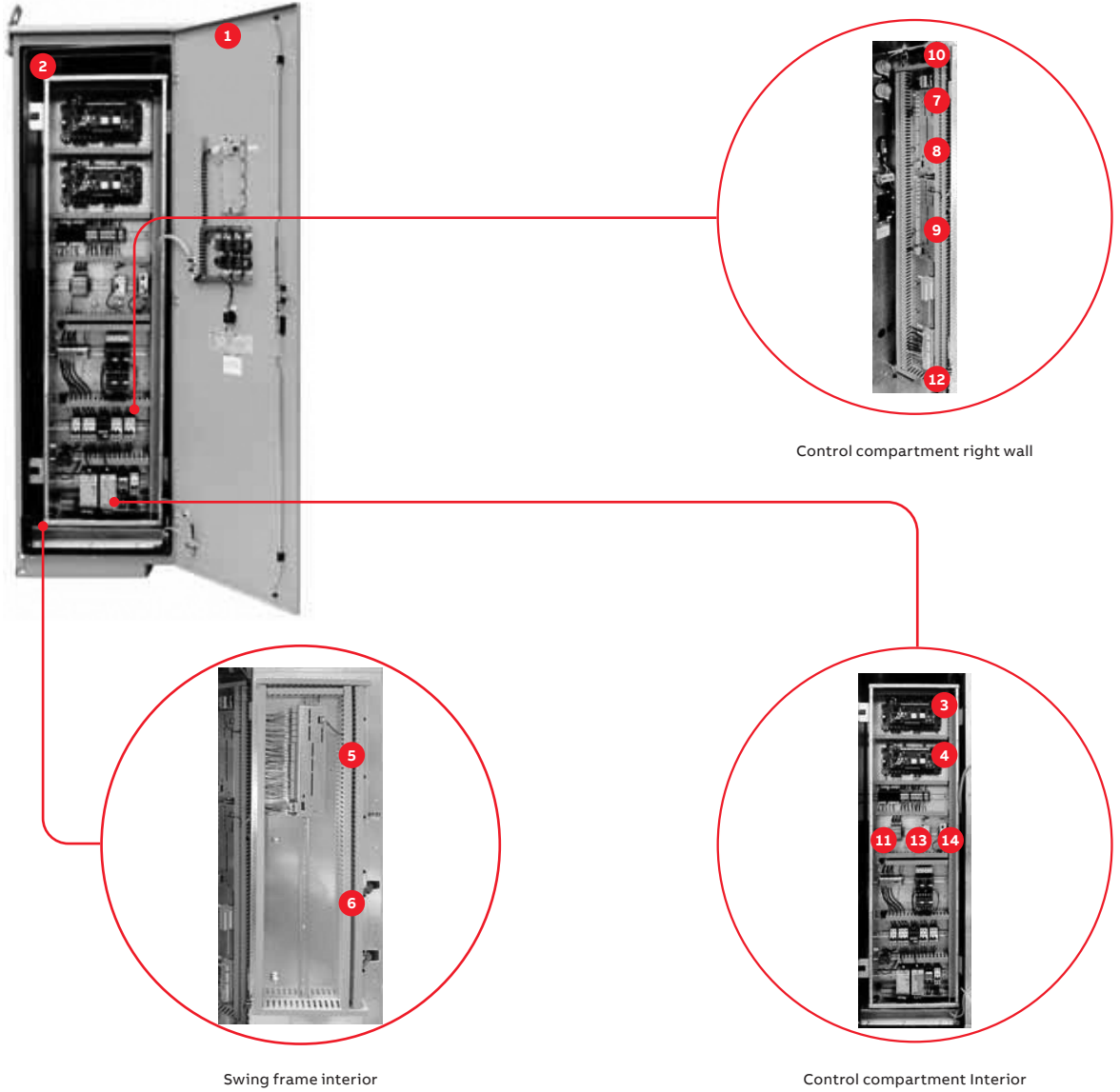

	1	Control compartment door
	2	Swing frame
Control compartment	3	INU (INverter Unit) circuit board
	4	AFE (Active Front End) circuit board
Swing frame interior	5	IOEC 1 communication module (internal drive I/O)
	6	IOEC 3 communication module (option) (internal drive I/O)
	7	Customer cable raceway
	8	IOEC 2 communication module (customer I/O)
	9	IOEC 4 communication module (option) (customer I/O)
	10	X10 MV (Medium Voltage) switchgear interface terminal block and X04 run lamp terminal block (option)
	11	Fieldbus adapter (option)
		X01 three-phase auxiliary power input X02 single-phase auxiliary power input (option) X19 motor heater protection input/output (option) X20 cabinet space heater input (option) terminal blocks
	12	
	13	Pulse encoder (option)
Right wall	14	Motor temperature supervision (option)

—
42
Simplified illustration
of control system

Control system configuration and main components

This section provides a brief functional overview of the main hardware components of the control system and their interconnection.

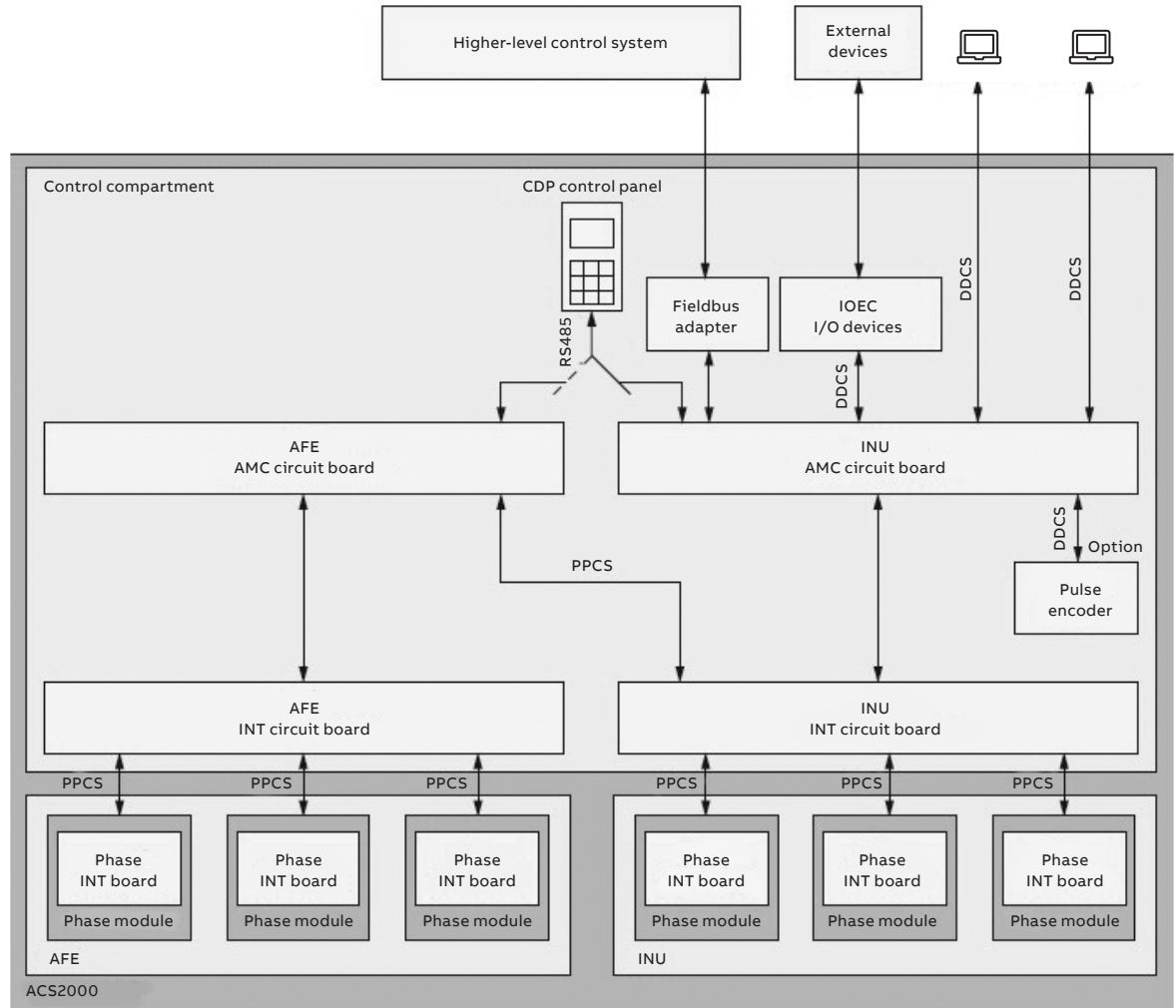

The control system is configured, customized and tuned with a set of application parameters. The application parameters are organized in functional groups and have factory-set default values.

The default parameter values are adjusted during commissioning to the specific application of the drive to activate the specific control, monitoring and protection functions for the driven process, and to define the signals and data to be transferred between drive and external equipment.

The parameters and parameter groups referred to in the signal allocation tables in this chapter are valid for drives with software version **LDAI60xx revision “-”** and later versions.



See Appendix M - Signal and parameter table, located on the CD, for detailed information on the parameters provided for signal allocation, signal type selection, signal inversion, scaling and filtering, etc.

AMC (Application and Motor Controller) circuit board

The major component of the drive's control system is the AMC circuit board. The AMC circuit board is a digital signal processor for general drive and motor control functions.

The drive control system has two AMC circuit boards. The AFE (Active Front End) circuit board and the INU (INverter Unit) circuit board are located inside the control compartment (see Figure 41).

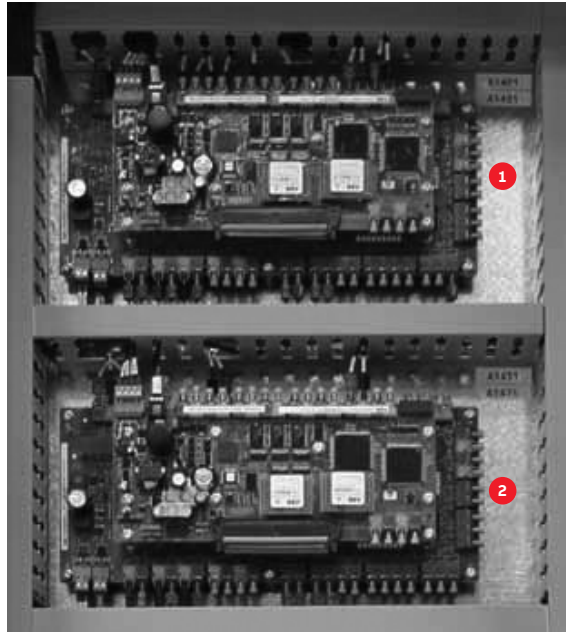

Control compartment interior

1	AMC and main INTERface circuit board of the INU
2	AMC and main INTERface circuit board of the AFE

Each circuit board is fitted with a 250 MHz Motorola DSP processor and features two PPCS and eight DDCS communication channels. These communication channels are used for high speed data transfer via the INT circuit boards to the Phase INT circuit boards inside the phase modules (see Figure 42).

The main internal control devices and the peripheral input and output interfaces to the customer communicate with the AMC circuit board via fiber-optic cables.

Communication with IOEC I/O system

The AMC circuit board of the INU and the IOEC I/O system communicate via two DDCS fiber-optic communication links, DDCS TX (for sending data), DDCS RX (for reading data), and an optional MCB-OFF optical input. The fiber-optic cables are connected to channel 7 of the AMC circuit boards.

Control tasks

Each AMC circuit board has specific control and closed-loop tasks assigned to it.

- The AMC circuit board of the AFE handles all rectifier and line-related functions of the drive
- The AMC circuit board of the INU handles all other control tasks. It processes drive and status information, performs the speed and torque control tasks, and monitors the operation of the drive

It continuously monitors all relevant drive variables (e.g. speed, current, voltage). Pre-programmed internal protection functions ensure that these variables remain within safe operating limits.

Optionally, the drive offers monitoring of signals from external equipment. These can be activated and adjusted by parameter settings.

Other general control, protection and monitoring tasks are implemented within the drive, including control and monitoring of the:

- MV switchgear
- Grounding switch
- Cooling system



See Appendix M - Signal and parameter table, located on the CD, for further information on control, protection and monitoring functions.

MV (Medium Voltage) switchgear

The MV switchgear is a major switching and protection device for the drive system.

This switchgear connects/disconnects the main power supply to the drive and is required to operate upon the drive's commands. The drive must have exclusive control over the switchgear as part of the pre-charge sequence of operation and discharging of the DC link.

NOTICE

Notice: The ACS2000 must have exclusive control of closing the MV switchgear. Uncontrolled closing of the switchgear may cause damage to the drive. See Appendix G - MV switchgear guide for control details. ACS2000 supplied with the optional integral input contactor disconnect has this switching integral to the drive. See Appendix P for details.

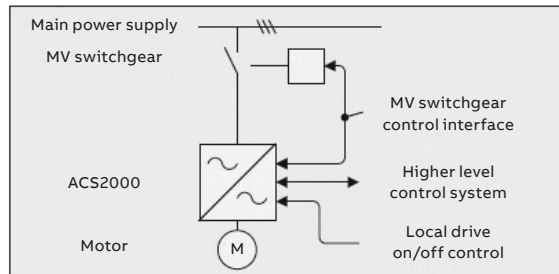

—
44
Typical single-line
drive system

—
45
DTC control platform

—
44

The switchgear disconnects the power supply when required by the process or when a fault occurs. Examples of switchgear compatible with the ACS2000 are MV circuit breakers, fused vacuum contactors or motor control centers.

On drives equipped with the integral input contactor disconnect option, the MV switchgear is integrated within the drive.



See Appendix G - MV switchgear guide, located on the CD, for further information.

See Appendix P - Integral Input Contactor Disconnect, located on the CD, for further information on drives with this option.

Speed and torque control

The speed and torque of the motor is controlled by DTC (Direct Torque Control). The DTC motor control platform, unique to ABB, provides accurate speed and torque control with high dynamic speed response. DTC is implemented on the AMC circuit board of the INU.

—
45

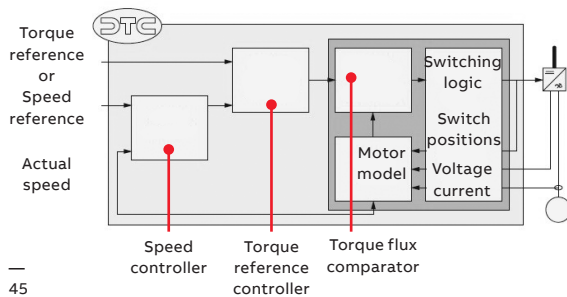

Switching of the semiconductors in the INU is directly controlled in accordance with the motor flux and torque.

The measured motor currents and DC link voltages are inputs to an adaptive motor model. The model produces estimated values of torque and flux every 25 microseconds. Motor torque and flux comparators compare the actual values to reference values which are produced by the torque and flux reference controllers.

Depending on the outputs from the hysteresis controllers, the switching logic directly determines the optimum switch positions every 50 microseconds and initiates switching whenever required.

Peripheral I/O devices

The peripheral input and output devices connected to the AMC circuit board of the INU include:

Local CDP control panel	See section Local control panel and Chapter CDP control panel
IOEC I/O system for parallel signal transfer to external devices	See section Interface system
Optional fieldbus adapters for data transfer to a higher-level control system	See section Fieldbus communication interfaces - optional
Pulse encoder	See section Pulse encoder (option)
Motor temperature supervision	See section Motor temperature supervision
PC-based service tools	DriveWare® software tools - includes software tools such as the commissioning and maintenance tools DriveWindow and DriveDebug, and DriveOPC for data transfer between ABB drives and Windows®-based applications DriveMonitor™ (Option) - a monitoring and diagnostics tool that allows access to the drive from any location in the world via a secure internet connection.

—
46
Local operator panel

—
47
CDP control panel
removal

Local control panel

The local control panel on the control compartment door serves as the basic user interface for monitoring, control and operation of the drive and setting of parameters.



1	CDP control panel
2	SUPPLY OFF/DISCHARGING
3	SUPPLY ON/CHARGING
4	FAULT/ALARM
5	GROUND SW RELEASED
6	Emergency OFF pushbutton

—
46

Features and functions of the CDP control panel

Features

The key features of the CDP control panel include:

- 4-line display
- User selectable display of actual values, e.g. motor speed, current, voltage, torque, power
- Fault memory to support maintenance

Functions

The CDP control panel allows the operator to:

- Enter start-up data into the drive
- Control the drive by setting reference values and by giving start, stop and direction commands
- Display three actual values at a time
- Display and set parameters
- Display information on the last 64 fault events

See chapter Local operation and chapter CDP control panel for further information.

Panel removal

The CDP control panel can be removed from its mounting cradle.

Before removing the CDP control panel during operation of the drive, check the setting of parameter 31.01 PANEL LOSS SUPERVISION. If the parameter is set to NOT USED, the panel can be removed without interrupting drive operation.



See Appendix M - Signal and parameter table, located on the CD, for further information on parameter settings.



Note: When the CDP control panel has been removed during operation, the drive can only be stopped by pressing the emergency-off button.

When removing the panel, proceed as illustrated below. After the panel has been removed, two LEDs are visible:

- The green LED (see 4 in Figure 47) is illuminated when the control voltage has been switched on
- The red LED is not used



1	CDP control panel
2	CDP removal
3	No CDP in place
4	Green LED

—
47

- 48 AMC circuit boards
- 49 IOEC I/O system overview
- 50 Module identification

Dimensions and weight

- Dimensions: (H x W x D) 170 x 80 x 21 mm [6.7 x 3.2 x 0.8 in]
- Weight: 0.2 kg [0.4 lbs]

Communication with AMC circuit board

The CDP control panel (1) is connected to the AMC controller of the INU (2) and AFE (3) of the drive via an RS485 interface. See Figure 48.

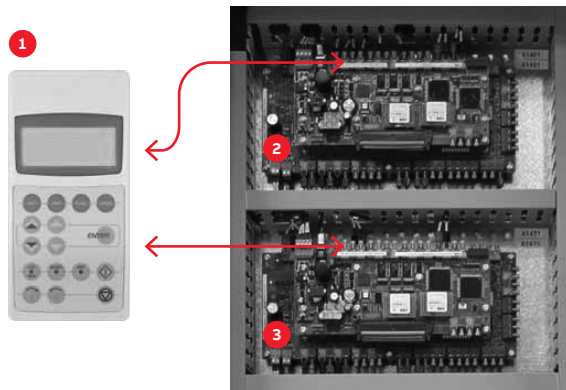

1	CDP control panel
2	AMC circuit board of the INU (INverter Unit)
3	AMC circuit board of the AFE (Active Front End)

— 48

Interface system

This section provides an overview of the control system used in the drive to transfer all the necessary functionalities of control, status, monitoring and protection signals between the drive and higher-level control systems or operator stations.

The following communication devices are available:

- IOEC modules 1 and 3 - internal to drive operation
- IOEC modules 2 and 4 - connection to external customer controls
- Fieldbus communication interfaces - option

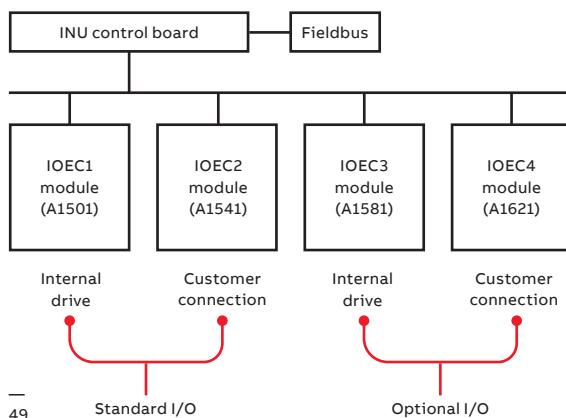

— 49

IOEC I/O

Overview

Internal and external, analog and digital I/O signals are connected to the control system by IOEC modules.

The standard I/O includes one customer communication module (IOEC2) and one module that is internal to the drive operation (IOEC1). The standard I/O provides standard control and supervision functionalities sufficient for most applications.

The drive can include optional expansion I/O that includes a customer communication module (IOEC4) and an internal module (IOEC3). These expansion modules provide extra inputs and outputs for control and supervision as may be required by ABB or the customer to support various control options.

IOEC modules

Each IOEC module is configured with both analog and digital inputs and outputs as shown in Table 9.

Table 9: IOEC module configuration

I/O signal	No. of I/O	I/O rating
Analog input	4	0...10 V or 0...20mA
Analog output	2	0...20mA
Digital input	14	20 to 240 VAC and 20 to 100 VDC
Digital output	6	6A at 230 VAC and 1A at 48 VDC

IOEC module identification

The I/O modules are identified on the part with an identification label, in the wiring diagram, and in the software by the wiring diagram identification number (e.g. -A1541, see Figure 50).

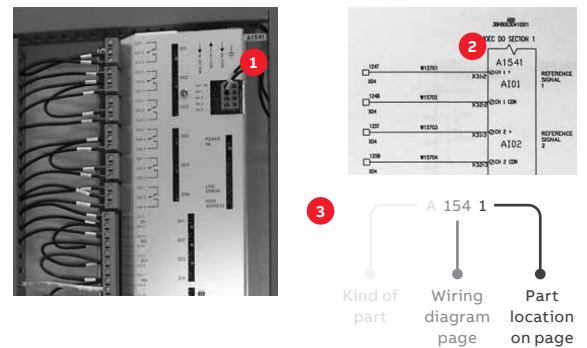

1	Identification label
2	Identification in wiring diagram
3	Identification number breakdown

— 50

Module identification

The way the identification number is built directly corresponds to the wiring diagram as can be seen in Figure 50. The letter A represents the kind of part we have, an assembly, the next three digits are the page number the part is located on, page 154, and the last digit, 1, means that our part is the first assembly on the page. This identification label number is the key to track electrical devices throughout the drive and in ABB documentation.

The designation for each IOEC module is shown in Table 10.

—
Table 10: Module identification

IOEC module	Wiring diagram designation for module identification
IOEC1	A1501*
IOEC2	A1541
IOEC3	A1581*
IOEC4	A1621

* No customer connections. Only for internal drive related use.

24 V internal voltage supply

One isolated DC/DC converter supplies an overload protected voltage of 24 V DC to operate digital inputs from passive contacts. The output is protected by a PTC-resistor against short circuit and external applied overvoltages.

—
Table 11: 24 V internal voltage supply

Output voltage	Available output current
Unregulated 24 V	180mA

Location

The IOEC modules are installed in the control compartment of the drive. The standard IOEC module internal to the drive is DIN rail mounted on the back side of the swing door. If there is an optional internal IOEC module, it will be mounted below the standard one.

The standard customer communication IOEC module is DIN rail mounted along the right side wall of the control compartment. If there is an optional expansion customer communication IOEC module, it will be DIN rail mounted just below the standard one.

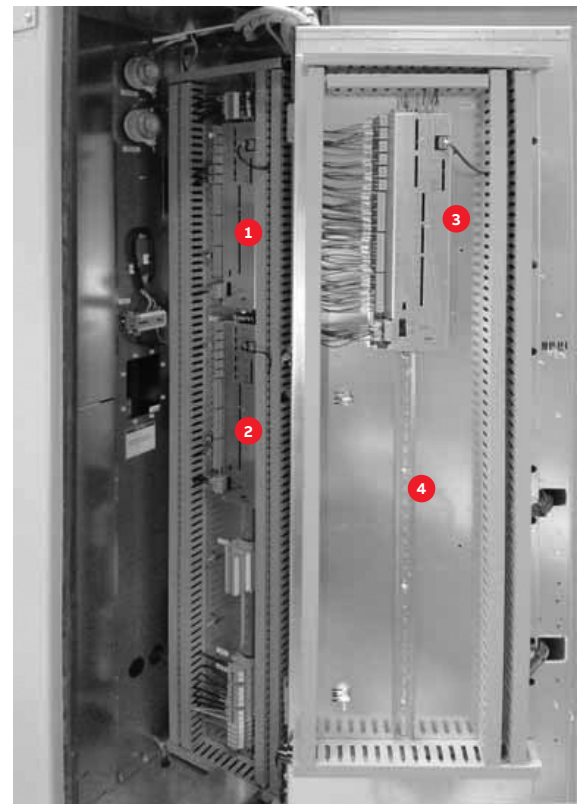

	Standard customer communication module IOEC2 (A1541)
1	Optional customer communication module IOEC4 (A1621)
2	Standard internal communication module IOEC1 (A1501)
3	Optional internal communication module IOEC3 (A1581)

Standard IOEC2 (A1541) customer communication module

The IOEC module has terminal blocks for internal wiring and indicator LEDs for diagnostic and I/O status. See Figure 52.

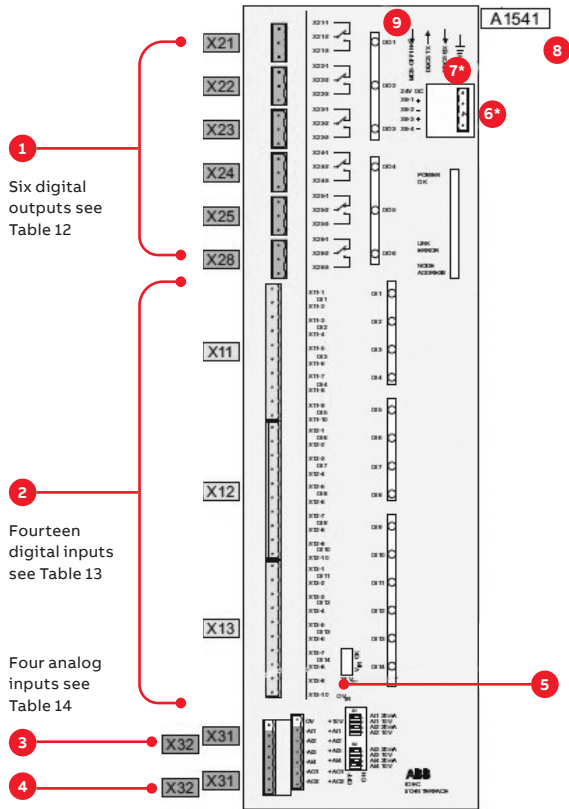

- 1 Digital outputs
- 2 Digital inputs
- 3 Analog inputs
- 4 Analog outputs
- 5 24 V internal voltage
- 6 Power supply *
- 7 DDCS fiber optics *
- 8 Module identification label
- 9 I/O Emergency OFF function *

IOEC2 (A1541) digital outputs

Table 12: Standard digital output signal allocation

DC voltage	Current Switching	Continuous
24 VDC	8 A	6A
48 VDC	1 A	6A
120 VDC	0.4 A	6A
AC voltage	Current Switching	Continuous
24 VAC	8 A	6A
48 VAC	8 A	6A
120 VAC	8 A	6A
230 VAC	8 A	6A

Terminal	Channel	Default setting
X21-1	DO01	NC NO Ready on (drive is ready for operation)
X21-2		
X21-3		
X22-1	DO02	NC NO Ready ref (drive is running)
X22-2		
X22-3		
X23-1	DO03	NC NO Alarm/fault (alarm is pending)
X23-2		
X23-3		
X24-1	DO04	NC NO Tripped (drive has shut down)
X24-2		
X24-3		

X10 Terminal block*	Terminal	Channel	Default setting
105T	X25-1 *		MV switchgear open command (low active)
104B	X25-2 *		
105B	X25-3 *	DO05	NC NO MV switchgear closed command (high active)
106B	X26-1 *		
106T	X26-2 *	DO06	
107T	X26-3 *		

* Factory installed wiring for X10 terminal block. See Appendix G - MV switchgear guide, located on the CD, for additional MV switchgear control information. When the integral input contactor disconnect is installed, X10 is internal to the drive. Refer to Appendix P.

—
53
Wiring example - start/
stop switch with 24
V internal supply

—
54
Wiring example - start/
stop switch with
external 120 V supply

IOEC2 (A1541) digital inputs

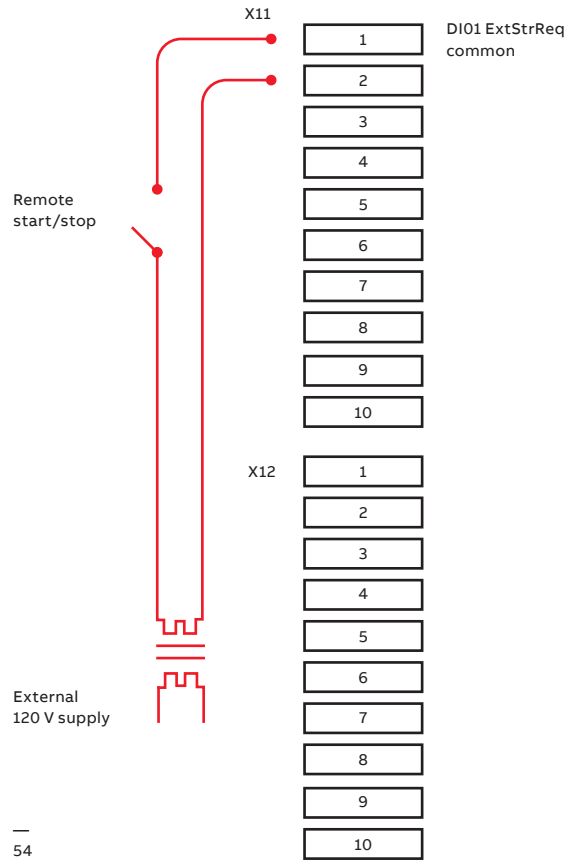
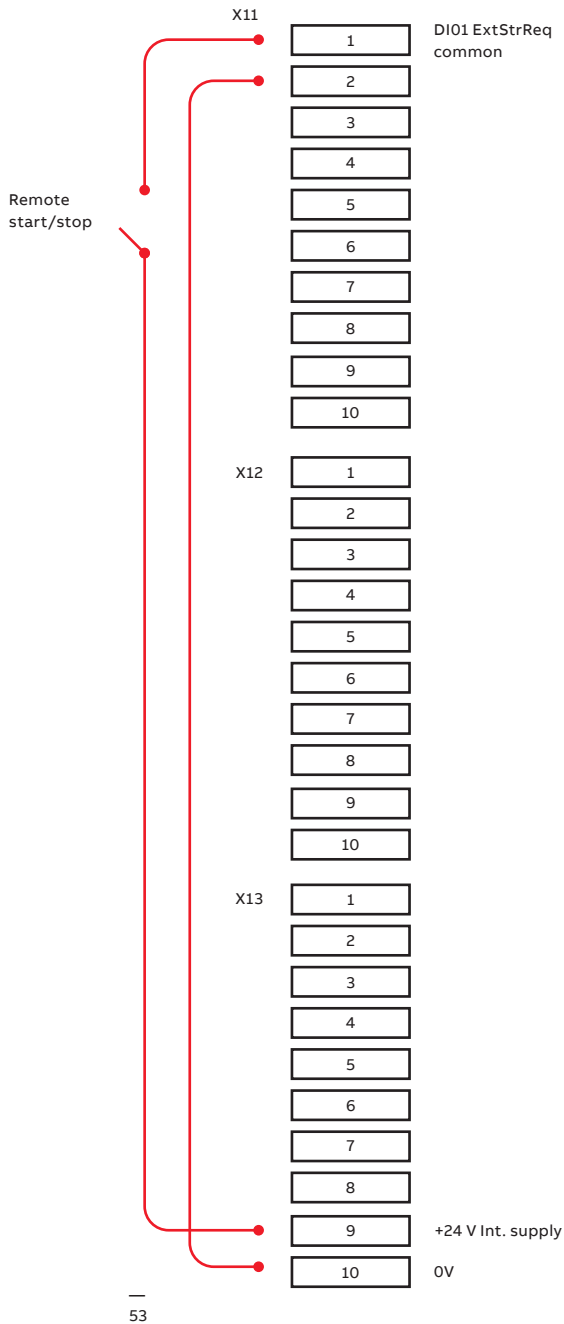

Table 13: Standard digital input signal allocation

Current	
Signal level direct	Typ 24 VDC max 100 VDC
Signal level alternating	Typ 24 VAC max 230 VAC
Input	8...25mA
Inrush 24 V	10mA
Inrush 120 V	Typ 65mA max 100mA

Table 13: Standard digital inputs signal allocation

Terminal	Channel	Default setting	Par. Group
X11-1	DI01	External start/stop request	72.06 to 72.09
X11-2		Common	
X11-3	DI02	Forward/reverse	72.10 to 72.11
X11-4		Common	
X11-5	DI03	Freely programmable	-
X11-6		Common	
X11-7	DI04	Ramp 1/2	72.41 to 72.42
X11-8		Common	
X11-9	DI05	Ext1/Ext2	30 to 31
X11-10		Common	
X12-1	DI06	Constant speed select	24 to 25
X12-2		Common	
X12-3	DI07	External on request (start DC link charge)	72.02 to 73.03
X12-4		Common	
X12-5	DI08	Process stop (stops drive)	72.43 to 72.44
X12-6		Common	
X12-7	DI09	MV switchgear open	*
X12-8		Common	
X12-9	DI10	MV switchgear closed	*
X12-10		Common	
X13-1	DI11	MV switchgear available (not tripped)	*
X13-2		Common	
X13-3	DI12	Remote reset	72.33 to 72.34
X13-4		Common	
X13-5	DI13	External OFF request	72.04 to 72.05
X13-6		Common	
X13-7	DI14	Disable local operation	72.35 to 72.36
X13-8		Common	
X13-9	+24 V	24 V control logic	-
X13-10	+0 V	Common	

* Not configurable. When the integral input contactor disconnect is installed, these signals are prewired.

IOEC2 (A1541) analog inputs

Table 15: Standard analog input signal allocation

Analog input resolution 10 bit	
Voltage mode	Current mode
Signal range 0...10 V	Signal range 0...20mA
Load impedance 250 kΩ	Load impedance 105 Ω

S1	<input type="checkbox"/>	AI1 20mA	S1	<input type="checkbox"/>	AI1 20mA
	<input type="checkbox"/>	AI1 10 V		<input type="checkbox"/>	AI1 10 V
	<input type="checkbox"/>	AI2 20mA		<input type="checkbox"/>	AI2 20mA
	<input type="checkbox"/>	AI2 10 V		<input type="checkbox"/>	AI2 10 V
S2	<input type="checkbox"/>	AI3 20mA	S2	<input type="checkbox"/>	AI3 20mA
	<input type="checkbox"/>	AI3 10 V		<input type="checkbox"/>	AI3 10 V
	<input type="checkbox"/>	AI4 20mA		<input type="checkbox"/>	AI4 20mA
	<input type="checkbox"/>	AI4 10 V		<input type="checkbox"/>	AI4 10 V
	OFF			OFF	
	ON			ON	

Remote speed supply output specifications

- Output voltage 10 V
- Available output current 5 mA

Terminal	Channel	Default setting	Par. Group
X31-1	+10 V	Internal supply voltage	-
X32-1	0 V		
X31-2	AI1+	Reference value 1 (speed reference)	
X32-2	AI1-		
X31-3	AI2+	Reference value 2 (speed or torque reference)	
X32-3	AI2-		
X31-4	AI3+	Motor winding V temperature	
X32-4	AI3-		
X31-5	AI4+	Motor winding W temperature	
X32-5	AI4-		

—
55
Wiring example -
remote speed
—
56
IOEC4 (A1621) module

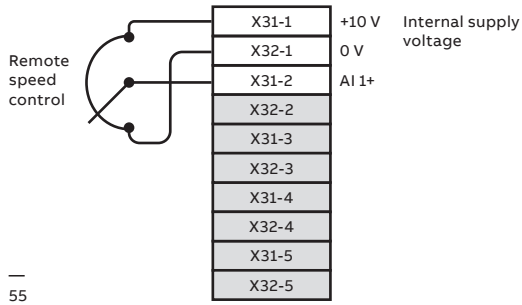

IOEC2 (A1541) analog outputs

- Analog output resolution 12 bit
- Signal level 0...20mA
- Load impedance 250 Ω

Table 16: Standard analog output signal allocation

Terminal	Channel	Default setting
X31-6	AO1+	Motor speed act
X32-6	AO1-	
X31-7	AO2+	Motor torque act filt
X32-7	AO2-	

Optional IOEC4 (A1621) customer communication module

The IOEC module has terminal blocks for internal wiring and indicator LEDs for diagnostic and I/O status. See Figure 56.

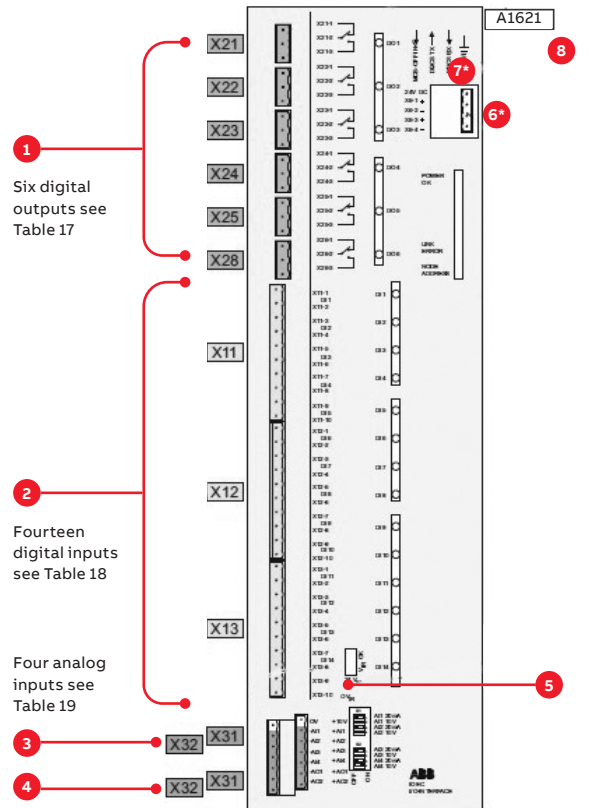

1
Six digital
outputs see
Table 17

2
Fourteen
digital inputs
see Table 18

3
Four analog
inputs see
Table 19

4
Two analog
outputs see
Table 20







1	Digital outputs
2	Digital inputs
3	Analog inputs
4	Analog outputs
5	24 V internal voltage
6	Power supply *
7	DDCS fiber optics *
8	Module identification label

*Factory installed wiring

IOEC4 (A1621) digital outputs

Table 17: Optional digital output signal allocation

DC voltage	Current Switching	Continuous
24 VDC	8 A	6A
48 VDC	1 A	6A
120 VDC	0.4 A	6A
AC voltage	Current Switching	Continuous
24 VAC	8 A	6A
48 VAC	8 A	6A
120 VAC	8 A	6A
230 VAC	8 A	6A

Terminal	Channel	Default setting
X21-1	DO01	 Freely programmable
X21-2		
X21-3		
X22-1	DO02	 Freely programmable
X22-2		
X22-3		
X23-1	DO03	 Freely programmable (for motor space heater then motor heater OFF command)
X23-2		
X23-3		
X24-1	DO04	 Freely programmable (for motor cooling fan then motor cooling fan ON command)
X24-2		
X24-3		
X25-1 *	DO05	 Freely programmable
X25-2 *		
X25-3 *		
X26-1 *	DO06	 Freely programmable
X26-2 *		
X26-3 *		

IOEC4 (A1621) digital inputs

Table 18: Optional digital inputs signal allocation

Current	
Signal level direct	Typ 24 VDC max 100 VDC
Signal level alternating	Typ 24 VAC max 230 VAC
Input	8...25 mA
Inrush 24 V	0mA
Inrush 120 V	Typ 65mA max 100mA

Terminal	Channel	Default setting
X11-1	DI01	Freely programmable
X11-2		Common
X11-3	DI02	Freely programmable
X11-4		Common
X11-5	DI03	Freely programmable
X11-6		Common
X11-7	DI04	Freely programmable
X11-8		Common
X11-9	DI05	Freely programmable
X11-10		Common
X12-1	DI06	Freely programmable
X12-2		Common
X12-3	DI07	Freely programmable
X12-4		Common
X12-5	DI08	Freely programmable
X12-6		Common
X12-7	DI09	Freely programmable
X12-8		Common
X12-9	DI10	Motor protection monitoring
X12-10		Common
X13-1	DI11	Motor vibration 2/bearing 2 (alarm trip)
X13-2		Common
X13-3	DI12	Motor vibration 1/bearing 1 (alarm trip)
X13-4		Common
X13-5	DI13	Ext mot trip (ovrtmp/ovrspd/space htr/fan)
X13-6		Common
X13-7	DI14	External motor alarm
X13-8		Common
X13-9	+24 V	24 V control logic
X13-10	+0 V	Common

IOEC4 (A1621) analog inputs

Table 19: Optional analog input signal allocation

Analog input resolution 10 bit	
Voltage mode	Current mode
Signal range 0...10 V	Signal range 0...20mA
Load impedance 250 kΩ	Load impedance 105 Ω

S1	<input type="checkbox"/> AI1 20mA <input type="checkbox"/> AI1 10 V <input type="checkbox"/> AI2 20mA <input type="checkbox"/> AI2 10 V	S1	<input type="checkbox"/> AI1 20mA <input type="checkbox"/> AI1 10 V <input type="checkbox"/> AI2 20mA <input type="checkbox"/> AI2 10 V
S2	<input type="checkbox"/> AI3 20mA <input type="checkbox"/> AI3 10 V <input type="checkbox"/> AI4 20mA <input type="checkbox"/> AI4 10 V	S2	<input type="checkbox"/> AI3 20mA <input type="checkbox"/> AI3 10 V <input type="checkbox"/> AI4 20mA <input type="checkbox"/> AI4 10 V
	OFF ON		OFF ON

Remote speed supply output specifications

Output voltage 10 V

Available output current 5 mA

Terminal	Channel	Default setting	Par. Group
X31-1	+10 V	Internal supply voltage	
X32-1	0 V		-
X31-2	AI1+	Motor winding U2 temperature	
X32-2	AI1-		
X31-3	AI2+	Motor winding V2 temperature	
X32-3	AI2-		
X31-4	AI3+	Motor winding W2 temperature	
X32-4	AI3-		
X31-5	AI4+		
X32-5	AI4-	Reserved	

IOEC4 (A1621) analog outputs

Table 20: Optional digital output signal allocation

Analog output resolution	12 bit
Signal level	0...20 mA
Load impedance	250 Ω

Terminal	Channel	Default setting
X31-6	AO1+	
X32-6	AO1-	Freely programmable
X31-7	AO2+	
X32-7	AO2-	Freely programmable

Fieldbus communication interfaces - optional

Overview

Fieldbus communication interfaces (also referred to as fieldbus adapters in the documentation) are used for the bidirectional communication between the drive and a higher-level process control system. Typically, operational commands, status messages of the drive, speed or torque reference values, and actual values are transmitted.

Communication with the AMC circuit board is done with datasets, each containing 3 x 16 bit integers. Each dataset contains a standardized set of process data. The content of the datasets is programmed accordingly in the remote control system.



Detailed information on data transmission and on data and signal allocation to the transmitted datasets can be obtained from:

- Appendix B - Fieldbus adapter manuals, located on the CD
- Appendix M - Signal and parameter table, located on the CD

Available fieldbuses

The drive can be equipped with one of the following fieldbus adapters.

Table 21: Fieldbus adapters

Fieldbus	Option code
Modbus	+FAMMO
Ethernet	+FAME0
Profibus DP/FMS	+FAMPO
Anybus DeviceNet Module	+FAMAD
Anybus EtherNet IP Module	+FAMAE
Anybus ControlNet Module	+FAMAC



See Appendix E - Wiring diagrams, located on the CD, to identify the adapter type installed in your drive.

See Appendix B - Fieldbus adapter manuals, located on the CD, for detailed information.

—
57
Fieldbus communication

—
58
Fieldbus location

Communication with AMC circuit board

The fieldbus adapter is connected to channel 0 of the AMC circuit board of the INU via fiber-optic cables.

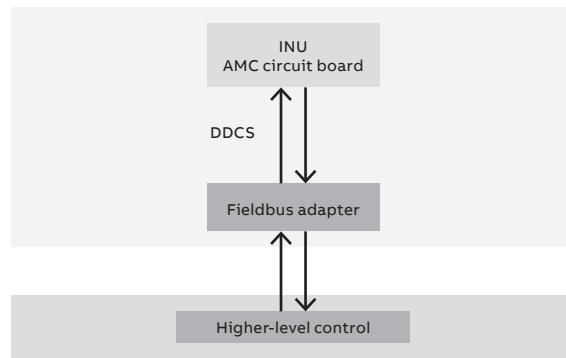

—
57

Location

The fieldbus adapter is mounted on a DIN rail inside the swing frame (see Figure 58).

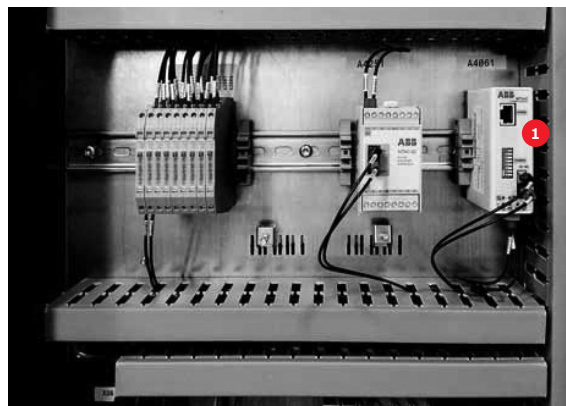

1 Fieldbus adapter

—
58

Pulse encoder (option)

The pulse encoder interface module option is required for constant torque applications.



See Appendix K - Pulse encoder, located on the CD, for detailed information.

Motor temperature supervision

Motor temperature supervision is accomplished via optional PT100 input modules. These modules are suitable for connection of PT100 resistance thermometers in accordance with IEC60751 in 2, 3 or 4 conductor systems.



See Appendix L - Motor temperature supervision, located on the CD, for detailed information.

Transportation, storage and disposal

59
Transport dimensions
(Frame 2 pictured)

Transportation

The transport conditions for the drive are based on IEC 60721-3-2 "Classification of environmental conditions: Classification of groups of environmental parameters and their severities; Transportation".

Classification: 2K4 / 2B1 / 2M1



See Appendix C - Technical data/environment/operation/Environmental/Transport, located on the CD, for detailed information.

Unpacking and inspection

Proceed as follows:

- 1 Remove all packaging material carefully. Do not use sharp or pointed tools.
- 2 Check the drive and accompanying equipment for damages.
- 3 Compare the complete delivery with the purchase order and the packing list.
- 4 If parts are missing or damaged, immediately inform the shipping company and the ABB service organization.

We recommend that you photograph the damages and send the photographs to ABB.

Lifting and transportation

Preparation is required to transport the ACS2000 drive properly. Take into consideration the height*, width, depth and weight of the drive.

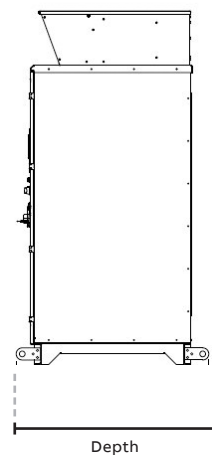
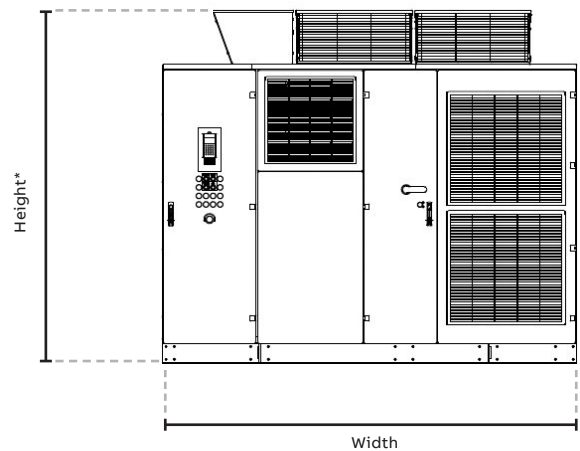

* The shipping pallet will add additional overall height.

—
60
Transporting the cabinet by crane using lifting brackets (Frame 3 pictured)

Have the following information at hand before transporting the cabinet:

- Appendix D - Mechanical drawings, located on the CD, provides details on specific dimensions and weight of the cabinet

General notes on transportation

Observe the following points when transporting the cabinet:

- The cabinet can be transported using a crane or a forklift
- Drive components can be damaged during transportation. Therefore, the cabinet must be transported in an upright position
- Measure the drive and make sure that the transportation path through any structures, such as doorways, is sufficient for the size of the drive
- Ensure that no dirt enters the cabinet during transportation. Keep the doors closed. Metallic dust in particular may cause damage and lead to malfunction when the drive is powered up

Using a crane

Observe the following points when using a crane:

- Use lifting equipment (web slings, chain slings, round slings, safety hooks, shackles, etc.) that corresponds to the size and weight of the cabinet
- Attach slings to the holes of the four lifting brackets using a spreader bar (see Figure 60)
- Do not pass a sling through the fastening hole
- Use appropriate safety hooks or shackles to attach a sling
- A spreader bar must be used when lifting the drive. Verify that the straps are no more than 5° from vertical (see Figure 60)



WARNING

WARNING: The drive should always be moved by level 2 certified rigger personnel.

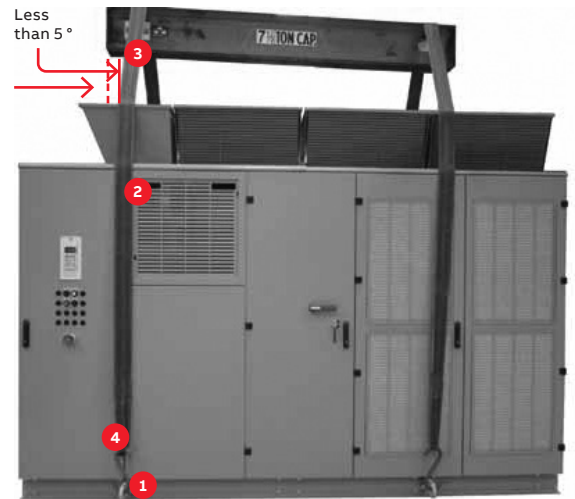

1	Lifting brackets - each corner
2	Slings
3	Spreader bar (not provided)
4	Lifting hooks

NOTICE

Maximum angle between lifting slings must be less than 5° from vertical.

- Lift the cabinet slowly and steadily to the required clearance height, keeping the cabinet in an upright position
- Check the horizontal position of the cabinet. Reposition the slings if necessary
- Care must be taken to ensure that the lifting straps do not damage the drive cabinet or fan boxes



Note: The lifting brackets can be removed after the cabinet has been installed at its final location.

Using a forklift

Observe the following points when using a forklift:

- Transport the cabinet by fully inserting the forks into the cabinet's forklift pockets either from the right or left side of the cabinet (see Figure 61)
- Do not attempt to lift entire cabinet, a forklift is only recommended when the opposite side is left to slide on the floor

—
61
Transporting the cabinet by forklift (Frame 2 pictured)

—
62
Frame 1 Prepare drive for storage

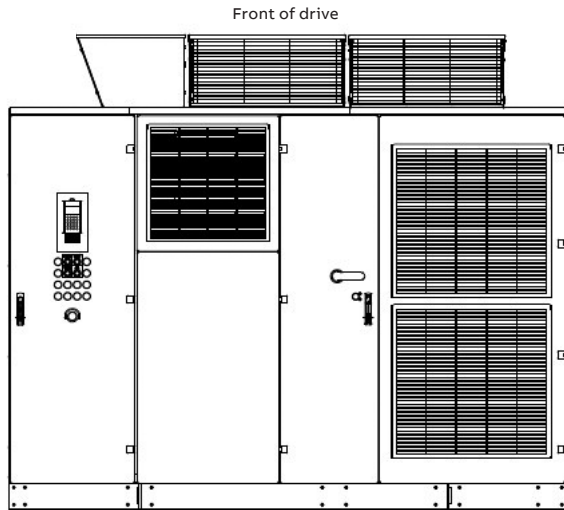

Side of drive

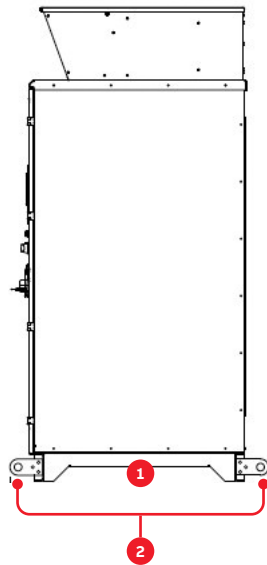

—
61

1	Forklift pocket
2	Lifting brackets

- Considering the drive cabinet length, use forks of sufficient length to ensure stable transportation and to prevent tipping
- Take care not to damage the cabinet
- Be careful when transporting to avoid tipping



Note: The lifting brackets (see 2, in Figure 61) are not used in this transportation method and can be removed.



See Appendix D - Mechanical drawings, located on the CD, for specific information on the dimensions and weight of the cabinet.

Storage

Storage conditions

The minimum requirements for storage are based on IEC 60721-3-1 “Classification of environmental conditions: Classification of groups of environmental parameters and their severities; Storage”.

Classification: 1K4 / 1Z3 / 1B1 / 1M3



See Appendix C - Technical data/ environment/operation, located on the CD, for detailed information.

The drive can be stored for up to one year in the original packaging as long as it is not damaged or opened. For information on longer storage periods contact the ABB service organization.

Storage

If the drive is taken out of service for an extended period of time, proceed as follows:

1. Cover all cable inlets and ventilation slots with an impermeable plastic or aluminum foil and a wooden panel.
2. Put a 0.5 kilogram [1 lb] bag of desiccant inside each of the two lockable compartments. (See Figure 62 - Frame 1, Figure 62 - Frame 2 or Figure 62 - Frame 3.)
3. Attach a humidity sensor tab inside each of the two lockable compartments. (See Figure 62 - Frame 1, Figure 62 - Frame 2 or Figure 62 - Frame 3.)
4. Close and lock the doors of the cabinet.

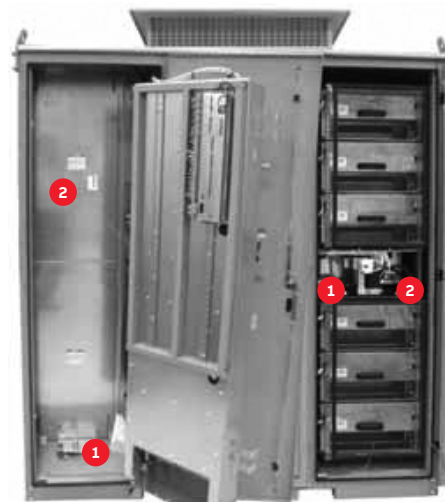

1	Desiccant bag
2	Humidity sensor tab

—
62

—
63
Frame 2 Prepare
drive for storage

—
64
Frame 3 Prepare
drive for storage

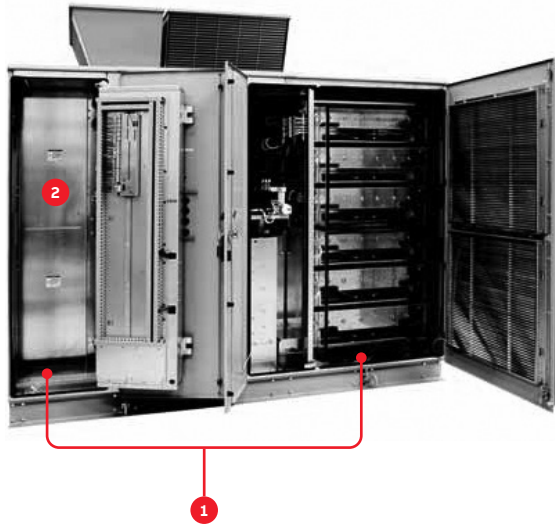

1	Desiccant bag
2	Humidity sensor tab

—
63

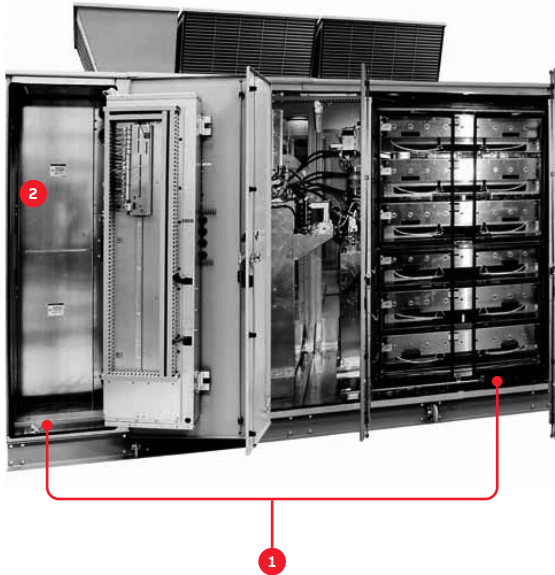

1	Desiccant bag
2	Humidity sensor tab

—
64

5. Use polyethylene or equivalent for packaging furnished:
- 0.3g/m²/24h water vapor diffusion

The storage conditions and the packaging should be checked regularly. Any damages that occur during the storage period should be repaired immediately.

Storage and handling instructions for spare parts

NOTICE

NOTICE: Static electricity can damage printed circuit boards.

Apply static-sensitive precautions when handling these components.

Inspect the spare parts immediately after receipt for damages. Report any damage to the shipping company and the ABB service organization.

Observe the following to maintain spare parts in good condition and to keep the warranty valid during the warranty period:

- Keep spare parts in their original packaging
- Store printed circuit boards in antistatic bags or boxes
- Storage temperature range: -5 °C to + 55 °C [23 °F to 131 °F]
- Storage place requirements:
 - Free of vibration and shock
 - Protected against dust, sand, vermin and insects
 - Free of corrosive gases, salt or other impurities that could damage electronic equipment.
 - Dry; no condensation
 - Relative air humidity: 5 to 85%
 - If in doubt whether the maximum allowed humidity may be exceeded, protect the spare parts with an external heater
- Apply static-sensitive precautions when handling printed circuit boards. Static electricity can damage these components
 - Do not touch a component without wearing a wrist grounding strap
 - Put the component on a grounded working surface, protected against electrostatic discharges
 - Hold the component only at the edge

Disposal of packaging materials and components

Dispose of the packaging materials and the components at the end of the lifetime of the drive according to local regulations.

Mechanical installation

Safety

All mechanical installation work must be carried out by qualified personnel according to the site and equipment requirements and in compliance with local regulations. See Chapter Safety, for information on how the safety messages are categorized and used in this manual.

Overview of installation procedure

Installation includes:

- Preparing the foundation
See section Foundation requirements.
- Mounting the drive to the floor
See section Base mounting.
- Installing the fan outlet box
See section Fan outlet box installation - Frame 1 (if required) or Fan outlet box and external fan installation - Frames 2, 3 (if required).
- Installing the optional redundant fan
See section Redundant fan installation - Frame 1 (option) or Redundant fan installation and removal procedures - Frames 2, 3 (option)

Installation site requirements

Ambient operation conditions

Ambient factors such as temperature, relative humidity, air contamination, shock and vibration must be in compliance with the stated maximum permissible levels.

Contact the ABB service organization if the condition of the installation site is not within the specifications or if the transportation or the installation require special measures.

- Maximum ambient temperature: see the drive rating label located on the back of the control compartment door
- Operation with respect to climatic and environmental conditions is based on IEC 60721-3-3
Classification: 3K3 / 3B1 / 3C2 / 3S2 / 3M3



See Appendix C - Technical data/environment/operation, located on the CD, for detailed information.

Foundation requirements

The floor must be a non-flammable, smooth, level, moisture-free surface able to support the weight of the drive.

—
Table 22: Cabinet weight

Frame	Standard weight kg [lbs]	With integral disconnect weight kg [lbs]
1	2495 [5500]	3130 [6900]
2	2950 [6500]	3585 [7900]
3	3855 [8500]	4490 [9900]

The floor must be flat overall within a recommended maximum slope of ≤ 5 mm [0.2 in]/5 m [16.4 ft].



See Appendix D - Mechanical drawings, located on the CD, for details on the specific weight of the cabinet.

See Appendix P - Integral Input Contactor Disconnect, located on the CD, for additional weight if this option is included on the drive.

Recommendations for cable ducts and fire protection

Cable ducts should be of non-flammable material with non-abrasive surface.

All cable entries and exits should be protected to prevent dust, humidity and animals from entering into the drive.

Suitable fire protection measures should be applied to prevent fire from spreading into the drive.

—
65
Anchor bolt

—
66
Direct-to-floor
base mounting

—
67
Frame 1 Fan outlet box

Drive installation

General notes on installation

NOTICE

NOTICE: When installing the drive, ensure that no dirt enters. Always close the doors when work is discontinued and completely cover openings. Metallic dust, in particular, may cause malfunction when the drive is powered up and may cause damage.

The cabinet roof is not designed as a mounting base for foreign devices, cable ducts, etc. Therefore, do not install any foreign device on the top of the drive.

Dimensions and clearances



See Layout drawing in Appendix D - Mechanical drawings, located on the CD, for specific information on the dimensions of the drive and clearances to be observed.

- Cabinet dimensions
- Clearances to be observed
- Mounting hole sizes

Base mounting

ABB recommends that the drive be attached to the floor during installation.

There is one acceptable means to attach the cabinet to the floor: direct-to-floor mounting.

Floor mounting hardware is not supplied by ABB.



—
65

Anchor bolts as illustrated or hardware as specified in the chart are recommended (see Figure 65).

Size	Grade	Dry torque value
M12	8.8	40 Nm
1/2 inch	5	45 ft-lbs

Direct-to-floor mounting

The cabinet provides a slot in each corner of the base to attach the drive to the floor.

Install the mounting hardware through slots outside the cabinet (see Figure 66).



1	Slot for screw
2	Cabinet frame

—
66

Fan outlet box installation - Frame 1 (if required)



1	Fan outlet box
---	----------------

—
67

- Dimensions: (L x W x H) 1150 x 840 x 180 mm [45 x 33 x 7 in]
- Weight: Approximately 37 kg [80 lbs]
- Tools : Torx screwdriver or 10 mm hex wrench to install the hexagon fastening screws

—
68
Fan outlet box
installation

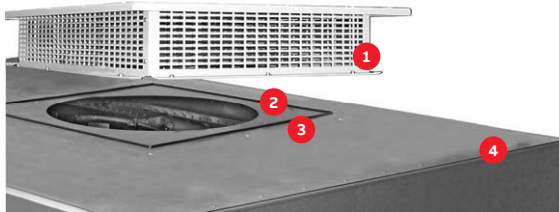

1	Fan outlet box
2	Sealing gasket
3	Predrilled holes
4	Top of drive

—
69
Frames 2, 3 Fan outlet
box and external fan
installation

—
70
Frames 2, 3 Fan outlet
box and external
fan installation

—
68

1. Consider the weight of the fan outlet box when lifting it onto the top of drive.

The box can be lifted by means of a forklift or a crane.

2. Being careful not to damage the sealing gasket, line up the outlet box holes with the predrilled holes in the top of the drive for proper orientation.
3. Fasten the fan outlet box to the top of drive by securing the supplied screws into the press nuts that are fitted on the underside of the predrilled holes.

Fan outlet box and external fan installation - Frames 2, 3 (if required)

The fan outlet box and the required fastening screws may be supplied separately.

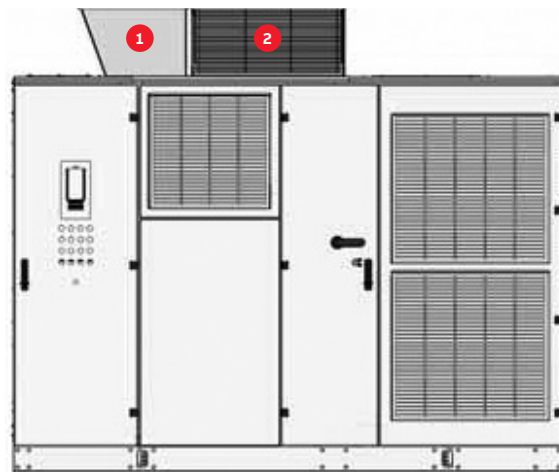

1	Fan outlet box
2	External fan

—
69

Tools

Torx screwdriver or 10 mm hex wrench to install the hexagon fastening screws.



See Appendix D - Mechanical drawings, located on the CD, for specific information on the dimensions and weight of the drive.



WARNING: Wiring connections will need to be made. Make sure no power is connected to the drive before proceeding with the fan installation.

Fan outlet box installation and removal procedures - Frames 2, 3

1. Consider the weight of the fan outlet box when lifting it onto the top of drive.

The boxes can be lifted by means of a forklift or a crane.

2. Remove the cover from the fan outlet boxes.
3. Being careful not to damage the sealing gasket, line up the outlet box holes with the predrilled holes in the top of the drive for proper orientation.

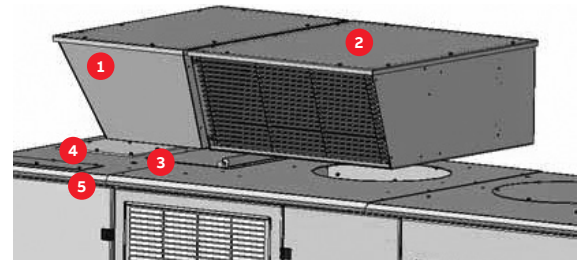

1	Fan outlet box
2	External fan
3	Sealing gasket
4	Predrilled holes
5	Top of drive

—
70

4. Fasten the fan outlet box and external fan to the top of drive by securing the supplied screws into the press nuts that are fitted on the underside of the predrilled holes.

—
71
Frame 2 External
fan power supply
connections

—
72
Frame 1 Redundant
fan unit

—
73
Frame 1 Redundant
fan box

5. Make the terminal block to drive wiring connections.

The rear panel of the external fan box may be removed for access to the wiring.

- A. Remove the upper IFU (Input Filter Unit) panel to access the drive wiring for the external fan.
- B. Carefully feed the wires from the drive up into the fan housing and route to the terminal block.
- C. Make the wiring connections.

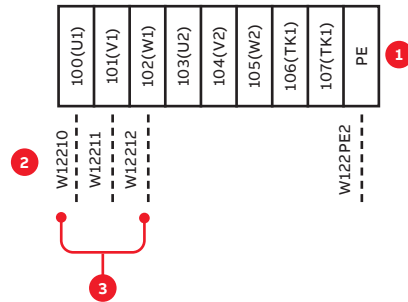

- | | |
|---|---------------------------|
| 1 | Terminal block X22 |
| 2 | Wire numbers |
| 3 | External fan power supply |

—
71

6. Check that the flapper is moving freely.
7. Reattach the rear and the cover of the external fan.

Removal procedure is the reverse of the installation procedure.

Redundant fan installation - Frame 1 (option)

The redundant fan unit and the required fastening screws are supplied separately.

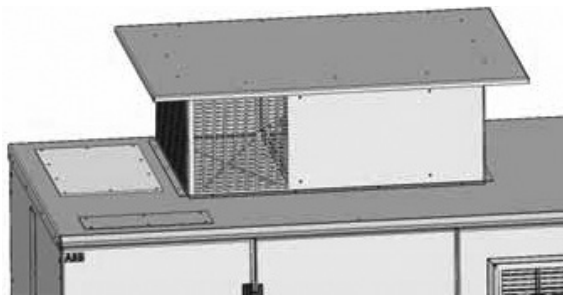

—
72

- Dimensions: (L x W x H) 1150 x 840 x 355 mm [45 x 33 x 14 in]
- Weight: Approximately 114 kg [250 lbs]

Tools

- Torx screwdriver for removing/installing the side panels of the fan
- or
- 10 mm hex wrench to install the hexagon fastening hardware



WARNING: Wiring connections will need to be made. Make sure no power is connected to the drive before proceeding with redundant fan installation.

Redundant fan installation procedure - Frame 1

Consider the size and weight of the components when planning to lift them onto the top of drive.

The fan components can be lifted by means of a forklift or a crane.

1. Remove the cover and the fan from the redundant fan assembly.

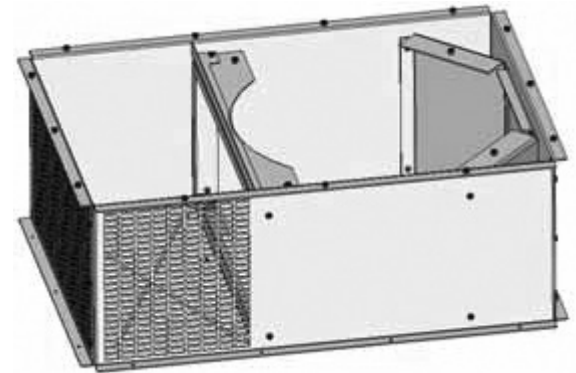

—
73

2. Remove the fan hole cover plate or the fan outlet box (if installed) from the top of the drive.
3. Lift and properly orientate the empty redundant fan box on top of the drive, being careful not to damage the sealing gasket.

—
74
Frame 1 Redundant fan installation

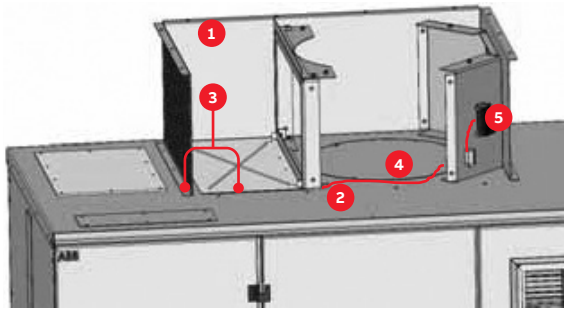

- | | |
|---|------------------------------|
| 1 | Redundant fan housing |
| 2 | Sealing gasket |
| 3 | Predrilled holes |
| 4 | Drive's redundant fan wiring |
| 5 | Terminal block |

—
75
Frame 1 Redundant fan power supply connections

—
76
Frame 1 Inlet ring installation

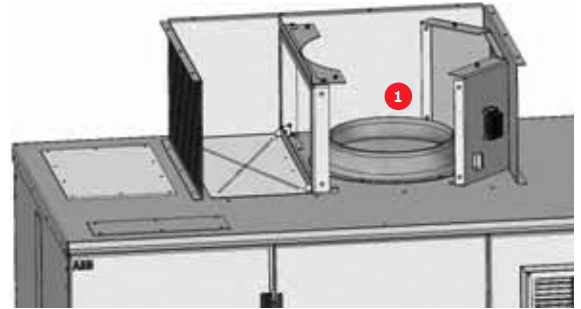

- | | |
|---|----------------|
| 1 | Fan inlet ring |
|---|----------------|

—
77
Frame 1 Fan installation

—
74

4. Fasten the fan unit using the supplied screws. The predrilled holes (see Figure 74 - Frame 1) are fitted with press nuts on the underside.
5. Make the terminal block to drive wiring connections.

The front wall of the fan box may be removed for easier access to the wiring.

- A. Remove the upper IFU (Input Filter Unit) panel to access the drive wiring for the redundant fan.
- B. Carefully feed the wires from the drive up into the fan unit housing and route to the terminal block.

C. Make the wiring connections.

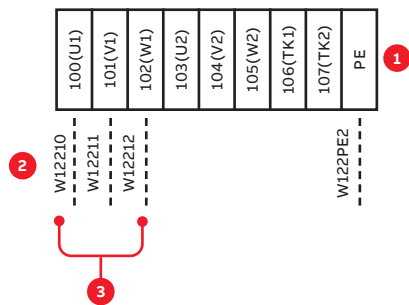

- | | |
|---|---------------------------|
| 1 | Terminal block X22 |
| 2 | Wire numbers |
| 3 | External fan power supply |

—
75

6. Bolt the fan inlet ring to the top of the drive.

—
76

7. Install the fan in the fan box.

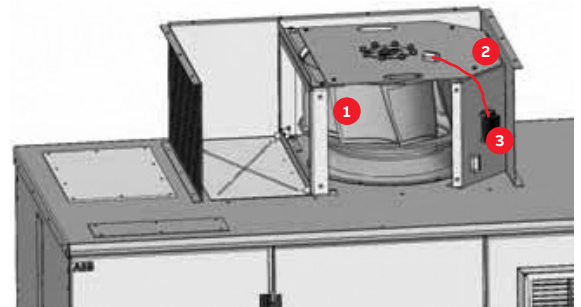

- | | |
|---|----------------|
| 1 | Fan |
| 2 | Fan wires |
| 3 | Terminal block |

—
77

8. Route the fan wires (see Figure 77 - Frame 1) and connect to the terminal block.

9. Check that the flapper is moving freely.

10. Reattach the front panel and the cover of the fan unit.

—
78
Frames 2, 3 Redundant
fan unit (Frame
2 pictured)

—
79
Frames 2, 3
Redundant fan box

—
80
Frames 2, 3 Redundant
fan installation

Redundant fan installation and removal procedures - Frames 2, 3 (option)

The redundant fan unit and the required fastening screws are supplied separately.

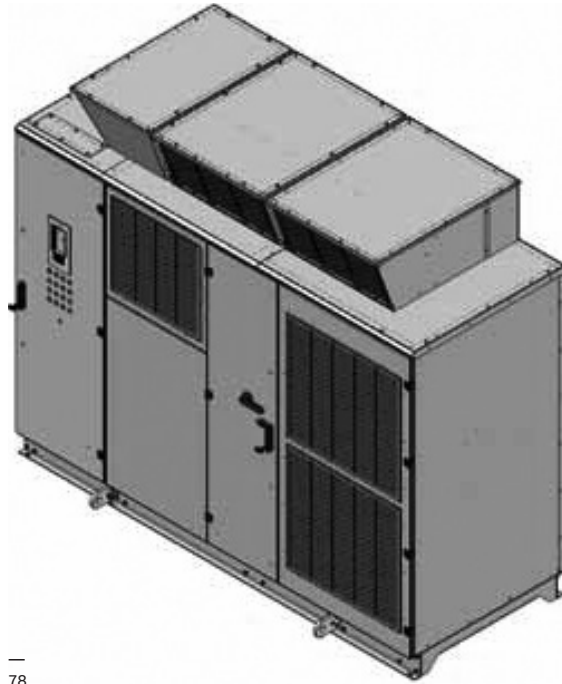

78

Tools

Torx screwdriver for removing/installing the side panels of the fan or 10 mm hex wrench to install the hexagon fastening hardware.



See Appendix D - Mechanical drawings, located on the CD, for specific information on the dimensions and weight of the drive.



WARNING: Wiring connections will need to be made. Make sure no power is connected to the drive before proceeding with redundant fan installation.

Redundant fan installation procedure - Frames 2, 3

Consider the size and weight of the components when planning to lift them onto the top of drive.

The fan components can be lifted by means of a forklift or a crane.

1. Remove the cover and the fan from the redundant fan assembly.

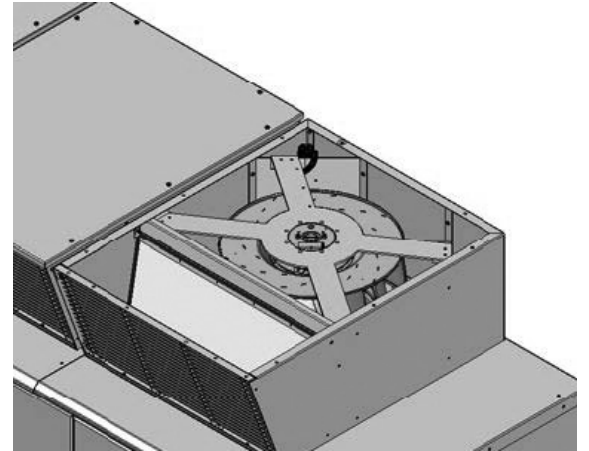

79

2. Remove the fan hole cover plate from the top of the drive.
3. Lift and properly orientate the empty redundant fan box on top of the drive, being careful not to damage the sealing gasket.

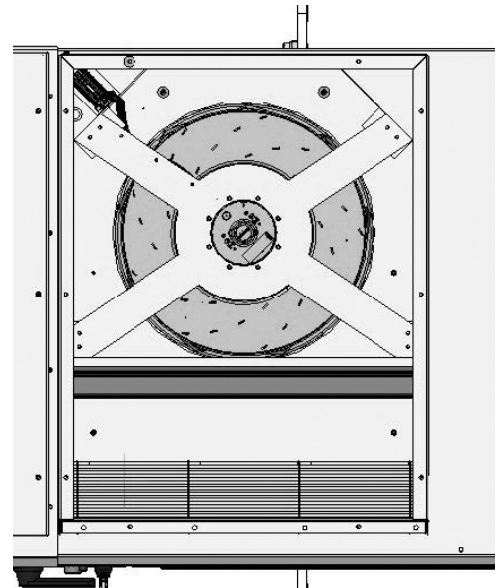

80

—
81
Frame 2 Redundant fan power supply connections

—
82
Frame 3 Redundant fan power supply connections

4. Fasten the fan unit using the supplied screws.
The predrilled holes (see Figure 77 - Frames 2, 3) are fitted with press nuts on the underside.
5. Make the terminal block to drive wiring connections.

6. Route the fan wires and connect to the terminal block.
7. Check that the flapper is moving freely.
8. Reattach the rear panel and the cover of the fan unit.

The rear panel of the fan box may be removed for easier access to the wiring.

Removal procedure is the reverse of the installation procedure.

- A. Remove the upper IFU (Input Filter Unit) panel to access the drive wiring for the redundant fan.
- B. Carefully feed the wires from the drive up into the fan unit housing and route to the terminal block.
- C. Make the wiring connections.

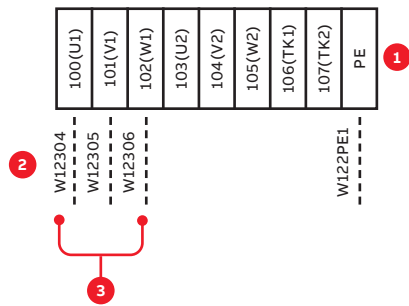

- | | |
|---|---------------------------|
| 1 | Terminal block X23 |
| 2 | Wire numbers |
| 3 | External fan power supply |

—
81

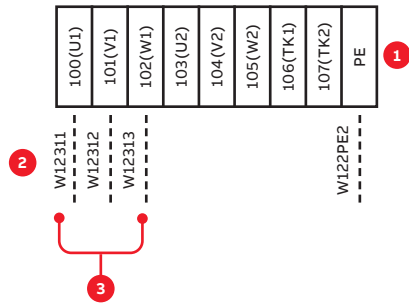

- | | |
|---|---------------------------|
| 1 | Terminal block X24 |
| 2 | Wire numbers |
| 3 | External fan power supply |

—
82

Electrical installation

Safety

All electrical installation work must be performed by qualified personnel according to the site and equipment requirements and in compliance with local regulations.

See Chapter Safety, for explanation on how the safety messages are categorized and used in this manual.

The main and auxiliary power supply to the drive must not be switched on without the consent of the ABB commissioning staff.



WARNING

WARNING: Hazardous voltage!

Improper work could lead to life-threatening injury or death.

The electrical installation must be carried out by qualified personnel according to the site and equipment requirements, and the relevant electrical codes.

When the electrical installation is completed, the main and auxiliary power supply to the drive must not be switched on without the consent of the ABB commissioning personnel.

Take appropriate measures to prevent main and auxiliary power supply from being switched on during installation or maintenance.

Isolating means (MV Switchgear)

Customer supplied or optional MV Switchgear is required for proper operation and maintenance of the ACS2000. The MV Switchgear must provide two functions.

1. Isolating means – The ACS2000 must have exclusive control of the MV Switchgear as part of the pre-charge sequence of operation and discharging of the DC link.



WARNING

NOTICE: The ACS2000 must have exclusive control of closing the MV switchgear. Uncontrolled closing of the switchgear may cause damage to the drive. See Appendix G - MV switchgear guide for control details. ACS2000 supplied with the optional integral input contactor disconnect has this switching integral to the drive. See Appendix P for details.

2. Interlocking – Interlocking by mechanical means (e.g. Kirk Key) is required in order to prevent the MV Switchgear from being opened or closed when the ground switch on the AFE/INU door is in the grounded position.

See Chapter Power electronics and cabinet features and Appendix G - MV switchgear guide, located on the CD, for additional details.

83
Isolating means

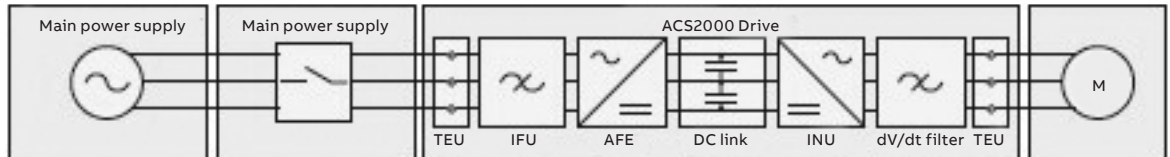

Overview of installation work

NOTICE

All cables and wiring must, at a minimum, follow the current NEC (National Electrical Code) Handbook requirements or equivalent, and must comply with all local codes. Any ABB recommendations will not replace these requirements.

Codes address cable selection from a safety and fire protection point of view; however, cables have a significant impact on the drive performance and reliability. Therefore, additional consideration is necessary for cable selection and installation to ensure safe and reliable operation.

The electrical installation includes the following wire and cable connections:

- Line supply and motor cables, ground cable and bonding conductors. See section Line supply and motor cables
- Auxiliary power and control cables. See section Auxiliary power, control and fieldbus communication cables

Cables and wires

Medium voltage power cables

Cable insulation

The cables to the main power input busses of the drive can be exposed to common mode voltages resulting from normal drive operation. For this reason, shielded cables rated 5 kV (phase to earth/phase to phase) or higher must be utilized. All power cables must be terminated with stress cones.

Three-core cables

A cable with three individually shielded conductors is recommended to ensure compliance with EMC (Electro Magnetic Compatibility) requirements, and to provide a low impedance high frequency path through which the common mode currents can flow. Shields should be terminated and grounded to a low impedance conductor at both ends. The drive includes a ground bus within the cable termination compartment in order to facilitate this.

A non-shielded three-core cable with a continuous corrugated aluminum armor may be used as an alternative. Steel armored or interlocked aluminum armored cable should not be used.

The maximum installed three-core cable length should not exceed 300 meters [1000 feet].



See Appendix H - Power Cable Specifications, located on the CD, for detailed cable information.

84
Trefoil arrangement
of single core cable

Single-core cables

Shielded single-core cables may be used, provided they are installed in a trefoil arrangement in order to prevent the occurrence of motor-bearing currents.

The maximum installed single-core, trefoil cable arrangement should not exceed 100 meters [328 feet]. Ground the shields at both ends.

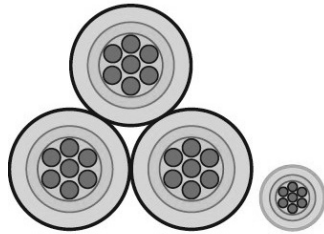

Ampacity rating

The ampacity rating of the line supply cables should be consistent with the percent required by national and local codes of the rated current of the drive being supplied, and the protection settings of the protection equipment.

The ampacity rating of the motor cables should be consistent with the size of the motor being supplied and the overload settings of the motor protection software.

Derating of cable ampacity in accordance with maximum expected ambient temperature, raceway fill factors, external heat sources, and any other factors required by local electrical codes should be applied.

Installation

Installation should be in compliance with national codes, local codes, and standard industry practice for medium voltage equipment.

Ground cable

It is important that the drive is properly grounded to maintain safety and to ensure reliable functioning of the equipment.

The ground cable must be securely tied to the ground system of the installation site and to the ground bus closest to the cable entry of the drive per national and local code requirements. See section Ground cable and cable shield connections for further information.

Cross-section

The cross-section of the ground cable and the ground connection must be in compliance with national and local electrical codes. Recommended minimum cross-section of ground cable: 50 mm² [1/0 AWG].

Bonding conductor

If the cross-sectional area of the shielding of the cables between the drive and the motor is less than half the cross-sectional area of that cable, an extra bonding conductor is required. Running the bonding conductor in parallel to the power cables is recommended to prevent shield overloading due to potential differences in the plant. See section Ground cable and cable shield connections for further information.

Cross-section (Bonding conductor)

The cross-section and ampacity rating of the conductor and the connection must be in compliance with national and local electrical codes.

Auxiliary power cables

A three phase 480 V cable is required for the standard auxiliary power supply (other voltages available by option). A neutral connector is not required. Type and rating is to be selected according to national and local code. Auxiliary power is wired into terminal block X01.

See Chapter Power electronics and cabinet features, for wiring details.

Control cables

Control cables should be provided in accordance with Table 23. Either single or multiple-twisted pair cables may be used.

Control cables should not be laid in parallel to the power cables. Attempt to keep a minimum distance of 30 cm [12 in] between control and power cables. Control and power cables should be crossed at an angle of 90°. Control cables are wired to the IOEC2, fieldbus adapter and terminal block X10.

See Chapter Control system, for wiring details.

—
85
Terminal entry unit

—
86
Cable entry

Table 23: Control cable requirements

Signal type	General cable type	Cross-section
Analog in	Twisted pair(s) - Overall shield	0.5 to 2.5 mm ² / 20 to 12 AWG
Analog out	Twisted pair(s) - Overall shield	0.5 to 2.5 mm ² / 20 to 12 AWG
Digital in	Twisted pair(s) - Overall shield	0.5 to 2.5 mm ² / 20 to 12 AWG
Digital out	Twisted pair(s) - Overall shield	0.5 to 2.5 mm ² / 20 to 12 AWG
Pulse encoder	Twisted pair cable with separately shielded pairs and overall shield	0.5 mm ² / 4 x (2+1) / 20 to 18 AWG

Cable entry

TEU (Terminal Entry Unit) for power cables and ground cable

The TEU for the power cables and the ground cable of the drive allows for either top or bottom cable entry.

The unused cable entry is closed by a cover (6).

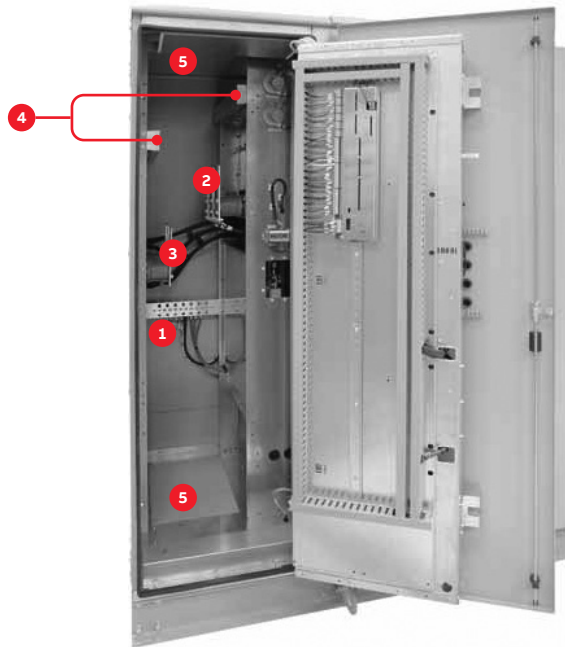

1	PE ground bus
2	Power IN terminals
3	Motor OUT terminals
4	Strain relief
5	Cable entry cover

—
85

Cable entry for ground cable, line supply and motor cables

Cable entry for ground cable, line supply and motor cables (1) is separate from the entry for auxiliary power and control cables (2).

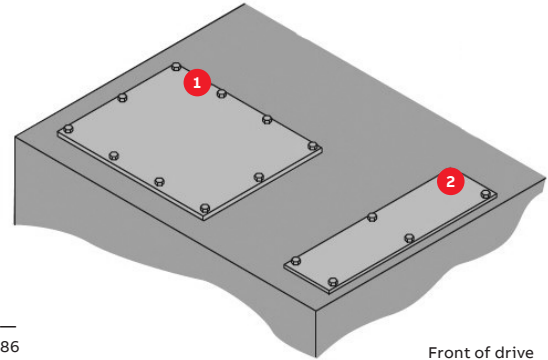

—
86

The entry plate for ground, line supply and motor cables (1 in Figure 86) is a 6.4 mm [0.25 in] thick aluminum plate. The entry holes need to be punched on-site to properly accommodate customer cables.

This aluminum plate is either attached to the top or the bottom access hole - whichever is receiving the cables.

The unused entry access hole is covered by a steel plate.

Cable entry for auxiliary power and control cables

The cable entry access holes for the auxiliary power and control cables (2 in Figure 86) are covered by an aluminum plate.

This aluminum plate needs to be punched on-site to properly accommodate the customer incoming cables.

This aluminum plate is either attached to the top or the bottom access hole - whichever is receiving the cables.

The unused entry access hole is covered by a steel plate.

—
87
Ground bus

—
88
Grounding and bonding
drive equipment

Ground cable and cable shield connections

The terminal entry unit is equipped with a ground bus to ground the cable armor and shield connections of the line and motor cables. Attach one lug per terminal.



1 PE ground bus

—
87

Ground cable and cable shield connections

The terminal entry unit is equipped with a ground bus to ground the cable armor and shield connections of the line and motor cables. Attach one lug per terminal.

Terminal details

- Busbar dimensions:
 - 75 mm [3 in] wide x 3.18 mm [0.125 in] thick
- Hole diameters:
 - 7 mm [0.28 in] for wire connections
 - 13 mm [0.5 in] for fastening bolt

Recommended grounding and bonding of the drive system

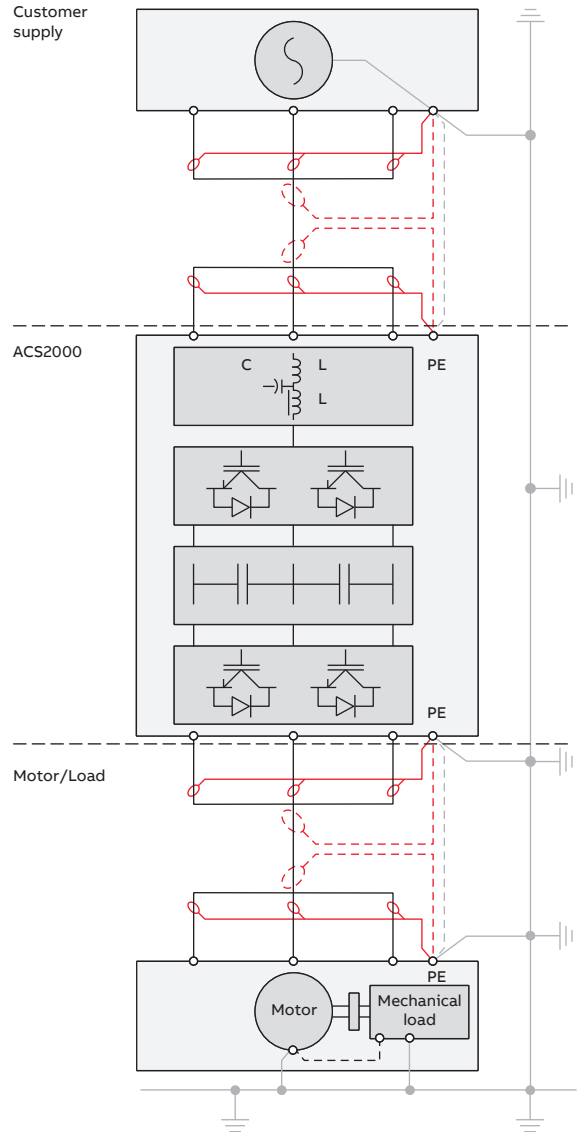

- Ground cable
- - - Bonding conductor
- - - Braid
- - - Cable shield
- - - Cable shield
- Earth electrode

—
88

—
89
Typical line and
motor cable



See Standard induction motor specifications for detailed cable information.

—
90
Typical cable entry

Line supply and motor cables

Further information



See Layout drawing in Appendix D - Mechanical drawings, located on the CD, for information on:

- Project specific cable entry
- Distance between point of cable entry and termination bars

See Appendix E - Wiring diagrams, located on the CD, for information on:

- Designation, cross-reference and device-identification conventions

Cable preparation



- | | |
|---|------------------|
| 1 | Copper shield |
| 2 | Ground conductor |
| 3 | Insulation |
| 4 | Copper conductor |

—
89

Determining the cable length

NOTICE

NOTICE: If possible, do not cut cables inside the terminal entry unit. Make sure that waste from cable cutting and stripping cannot enter the cabinet. Any waste which is accidentally dropped into the cabinet must be removed. The waste could cause damage or malfunction.

Enter the cables into the terminal entry unit to measure the conductor length.

Mark the required conductor length, withdraw the cable and cut it to the correct length.

Cable entry

Enter the cable through the entry plate and secure per national and local code requirements.

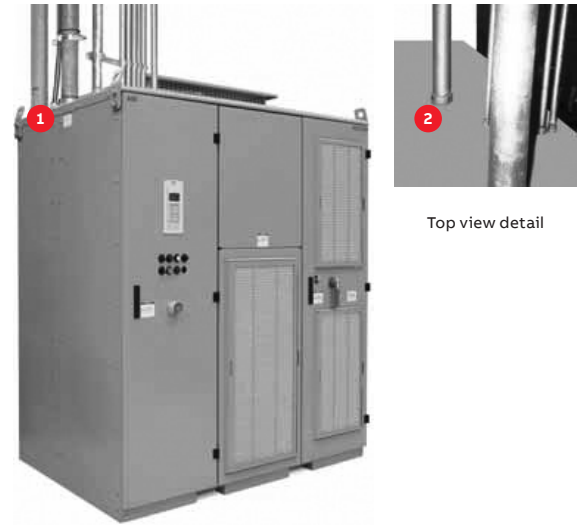

Top view detail

- | | |
|---|-----------------|
| 1 | Cable entry |
| 2 | Cable connector |

—
90

Stress cones

Shielded power cables must be terminated with stress cones and two-hole lugs. The lug holes need to accept M12 [0.5 in] bolts, and accommodate standard IEC (50 mm) or NEMA [1.75 in] two-hole patterns.

Checking cable insulation

Check the insulation of each cable with a megger before connecting it and verify that the results are within the specification of the cable manufacturer.

Leave the cable conductors unconnected at both ends until the commissioning engineer has given his permission.

Cable connection

Cable lugs

Mount cable lugs suitable for M12 or 0.5 inch bolts. Cables must be terminated with lugs according to the specification of the cable manufacturer.

—
91
Busbars

—
92
Connection with Belleville
spring and flat washer

Busbars

Connect the cables to their corresponding busbars.

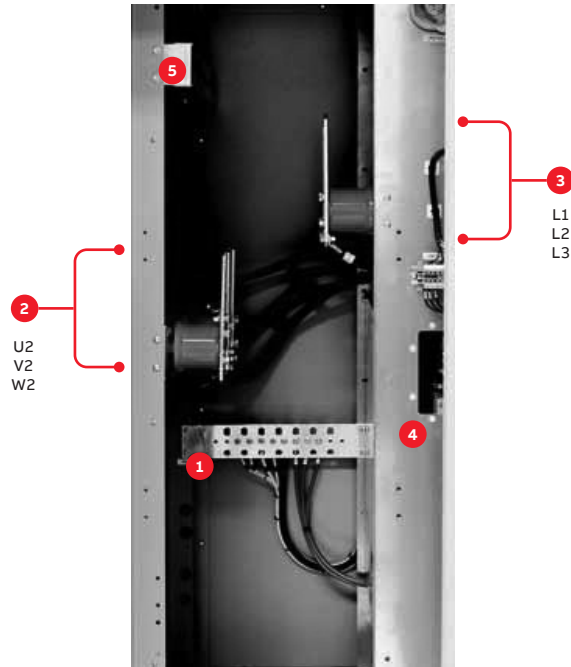

1	PE ground bus
2	Power OUT
3	Power IN
4	Fuses
5	Strain relief

—
91

- Connect the line supply cable conductors to busbars L1, L2, L3
- Connect the motor cables to busbars U2, V2, W2
- Connect the shielded ends of all conductors and the shield of all cables to the PE (Protective Earth) ground bus (1 or 6 in Figure 91)
- Connect the ground cable to the PE ground bus (1 or 6 in Figure 91)

NOTICE

NOTICE: High voltages will be present in the terminal entry unit. High voltages can cause flashover between the potential of different phase conductors and the potential of a phase conductor and earth.

Therefore, a minimum clearance of 55 mm [2 in] must be maintained between each cable and the terminals of any other phase, and a minimum of 75 mm [3 in] from each cable to any exterior cabinet wall.

Busbar details

- Busbar thickness: 6.4 mm [0.25 in]
- Hole diameter for fastening bolts: 13 mm [0.5 in]
- The busbars are suitable for both IEC and NEMA lug-type cable connectors

Bolted busbar connections

Material requirements

Use galvanized bolts and nuts as specified in Table 24.

Table 24: Hardware requirements

Bolt size	Grade	Dry torque value
M12	8.8	54 Nm
1/2 inch	5	40 ft-lbs

Connection type

This connection (see Figure 92) is recommended when connecting a cable lug (3) to a busbar (4):

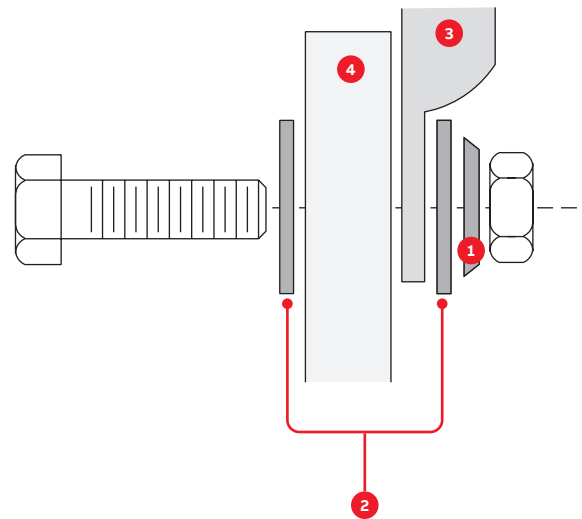

1	Belleville washer
2	Flat washer
3	Cable lug
4	Busbar

—
92

- 93
Typical busbar connections
- 94
Check power fuses



—
93

Tightening torque

Tighten bolted connections with bolts of sizes M12 or 1/2 inch and greater with the recommended nominal torque for the bolt size used. See Table 24 for torque values.

Fuses

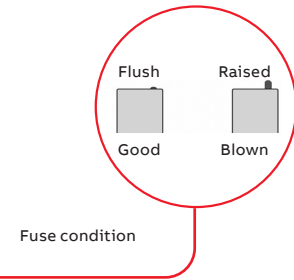

Site window detail (Behind swing frame)

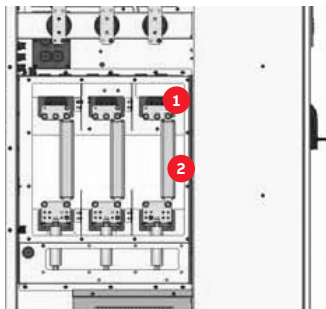

- 1 Red indicator pin
- 2 Fuse

—
94

Check that the power fuses are securely bolted and torqued in place. Torque value is 20 Nm [15 ft-lbs]. Check that the electrical wires are attached to both ends of the fuses. Make sure the fuses are not blown. The red indicator pin should be flush with the top of the fuse. See Figure 94.

If one fuse has blown, the other fuses may be degraded. ABB recommends that all fuses be replaced.

Fuse specifications

The power fuses are specified in Table 25.

—
Table 25: Power fuse ratings

Drive rating kW [hp]	Current rating (A)	ABB part number	Quantity per phase
Frame 1			
224-298 [300-400]	80	2UEA001267	1
336-522 [450-700]	140	2UEA001268	1
597-746 [800-1000]	200	2UEA000093	1
Frame 2			
933 [1250]	140	2UEA001268	2
1119-1492 [1500-2000]	160	2UEA002203	2
Frame 3			
1679-2238 [2250-3000]	230	2UEA001947	2

 See Appendix P - Integral input contactor disconnect, located on the CD, for fuse location on drives with this option.

Final checks

Check that the entry plates are properly fastened. If rubber grommets are used, check that they fit tightly to prevent water from entering the cabinet. If necessary, seal the gaps with silicone rubber.

Auxiliary power, control and fieldbus communication cables

Further information

 See Layout drawing in Appendix D - Mechanical drawings, located on the CD, for information on:

- Project specific cable entry
- Dimensions between point of cable entry and terminals

—
95
Auxiliary, control, and
fieldbus cable entry



See Appendix E - Wiring diagrams, located on the CD, for information on:

- Designation, cross-reference and device-identification conventions

Cable preparation

The control cables are entered either through the top or the bottom of the terminal entry unit.

Punch the aluminum plate being used for cable entry as required for the cables.

Cable routing

Route the cables through the steel access plate to termination on the right side wall in the control compartment where the IOEC I/O control connections and the fieldbus interface devices are rail mounted.

See Chapter Power electronics and cabinet features, Auxiliary power supply for auxiliary current and power specifications.

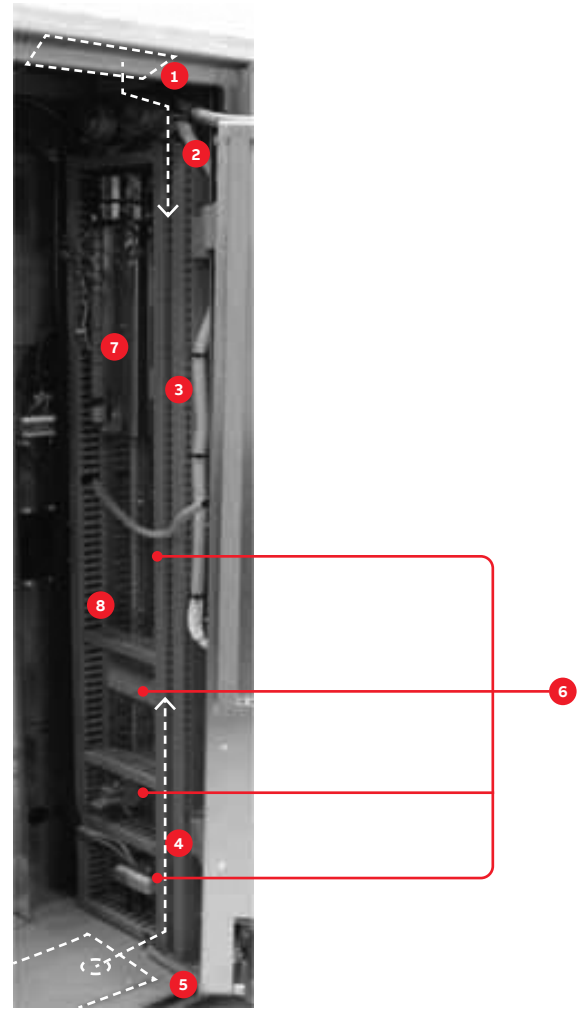

1	Top access panel
2	Top cable route
3	Customer raceway
4	Bottom cable route
5	Bottom access panel
6	PE terminals
7	Standard IOEC2 customer communication module
8	Optional IOEC4 customer communication module

Determining the cable length

Determine the required length of a cable between the point of entry and the connection point inside the cabinet and cut the cable to the required length before connection to avoid excess cable in the raceway.

Cable connection

- Connect all cables according to Appendix E - Wiring diagrams, located on the CD
- Connect cables for digital and analog input and output signals to the IOEC2 and 4 modules on the left wall of the control compartment
- Connect control cables for the MV switchgear to the X10 terminal block and IOEC2 module



See Appendix G - MV switchgear guide, located on the CD, for detailed cable connection information.

- Connect fieldbus communications cables directly to the fieldbus interface
- If twisted pair cables are used, leave the unshielded cable ends twisted until they reach the terminals
- Connect the individual cable shields to the PE terminals
- Use the supplied customer cable raceway to fasten the cables. See 3 in Figure 95

Terminal sizes

The terminals are suitable for wires with a maximum cross-section of 0.2 to 2.5 mm² [24 to 12 AWG]. Maximum torque is 2.0 Nm [17.7 in-lbs].

The PE terminals can accommodate shielded cables up to 17 mm [0.67 in] in diameter.

Commissioning

Required qualification

Commissioning, parameter adjustments and functional tests are only to be performed by qualified commissioning personnel certified by ABB.

Procedure

Information on the commissioning procedure and the start conditions for commissioning can be obtained from ABB.

See section General information on manual and equipment for contact information.

Checklist

In order to ensure uncomplicated and speedy commissioning, it is important that drive and associated equipment are ready for commissioning. Reviewing and completing the items in the Commissioning checklist before the commissioning personnel arrive on site will help to achieve this.

Customer assistance

During the commissioning period, the customer is requested to provide qualified personnel for assistance, who are:

- Experienced with medium and low voltage equipment and with the local safety regulations
- Familiar with the driven process
- Authorized to operate associated medium and low voltage equipment (MV switchgear, other low and medium voltage switchgear, etc.)
- Authorized to operate the driven process for functional tests

Customer acceptance

When commissioning has been completed, the commissioning report is signed by the responsible commissioning personnel and by the customer as a sign of acceptance. A copy of the report and a copy of the actual parameter settings are presented to the customer.

Commissioning checklist

Mechanical installation

1. Drive installed according to the instructions in the User manual
2. Drive securely fastened to the floor (if applicable)
3. Fan outlet box or optional redundant fan unit installed
4. Visual inspection:
 - no loose or damaged components

Electrical installation

1. Types and cross sections of control cables suitable for the signal type and signal level
2. Types and cross sections of power cables selected according to the ABB power cable specification
3. Pulse encoder cable shields connected to “shield grounding point” and not connected directly to the pulse encoder interface (only applicable for drives with pulse encoder option)
4. Cable entry made according to the instructions in the User manual
5. All control cable shields and conductors are connected according to the instructions of the User manual, appropriately labelled, and the customer-side connections are completed

- 6. Ground cable of drive securely connected at both ends and power cable shields grounded at both ends
- 7. Line supply and motor cables not connected at both ends (cables and drive must be meggered before connection)

MV switchgear

- 1. Type of MV switchgear selected and wired per ABB MV switchgear specification
- 2. MV switchgear ready to be tested with drive
- 3. MV switchgear protection relay settings tested
- 4. Safety devices (door locks, Kirk® key, grounding switch, etc.) tested and in operation
- 5. **MCB IS EXCLUSIVELY CONTROLLED BY THE ABB DRIVE**

Motor

- 1. Motor installed, aligned and alignment protocol available
- 2. Motor not coupled to driven load
- 3. Ground connection completed
- 4. Motor auxiliaries (bearing lubrication, heater cooling, etc.) ready

Insulation tests

- 1. All power cables to input transformer, between input transformer and drive, and from drive to motor are meggered, and measured values are within the required limits
- 2. Test report of the megger test available



Note: If the test is carried out by the commissioning engineer of the drive, an additional day per drive motor combination needs to be reserved. The test must comply with the specification.

Power supply

- 1. Medium voltage available for start-up of drive
- 2. Low voltage auxiliary power available for start-up of drive according to the instructions in the User manual

Miscellaneous

- 1. Sufficient number and correct type of spare parts available
- 2. Air conditioning of drive room ready for load run of drive
- 3. Optional equipment ready

Local operation

96
Local operator
panel functions

Overview

This chapter outlines the local operation using the CDP control panel and the control pushbuttons on the control compartment door of the drive as illustrated in section Overview of local operator panel.

Control of the drive via a PLC or higher-level control systems is not described in this chapter. If the drive is controlled remotely, see the appropriate manuals for information.

Safety

Only qualified personnel shall operate the drive system, i.e. personnel who are familiar with the operation of the drive system and the hazards involved. See Chapter Safety for information on how the safety messages are categorized and used in this manual.

Local operation

Overview of local operator panel

The operator panel on the control compartment door enables the operator to control the drive without restrictions provided that all requirements for normal operation are met.

The functions of the operator panel include:

- Connecting/disconnecting the main power supply
- Setting the reference value
- Starting, stopping the drive system
- Displaying:
 - Actual values
 - Status messages
 - Alarm and fault messages
- Viewing, setting parameters
- Resetting alarm and fault messages
- Activating the emergency-off circuit
- Testing the bulbs of pilot lights and illuminated pushbuttons

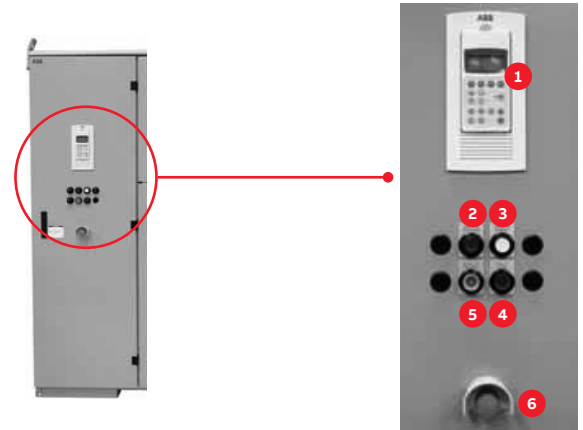

			Starts and stops the motor
			Displays status messages of AFE (Active Front End) and INU (INverter Unit)
1	CDP control panel*	-	Displays alarm/fault messages of the drive and monitored equipment
	SUPPLY OFF pushbutton / DISCHARGING / pilot light	green light	Discharging - opens the MV switchgear and initiates discharge of the DC link
2			Solid on: DC link discharged
	SUPPLY ON pushbutton / CHARGING / pilot light	white light	Flashing: charging or discharging
3			Charges the DC link and closes the MV switchgear
	FAULT / ALARM pilot light	blue light	Flashing: charging or discharging
4			Solid on: DC link energized (MV switchgear closed)
	GROUND SW RELEASED pilot light	yellow light	Flashing: alarm
5			Solid on: fault
	Emergency OFF pushbutton	-	Solid on: indicates that the grounding switch can be turned
6			Removes power when pressed:
			MV switchgear opens immediately and DC link discharges
			Motor coasts to a stop

* See Chapter CDP control panel for further information on the CDP control panel.

Lamp-test function

The bulbs of pilot lights and illuminated pushbuttons on the control compartment door (2, 3 and 4 in Figure 96) can be tested with the lamp-test function.

The lamp test is activated via the CDP control panel by setting parameter 16.7 to lamp test. The lamp-test function resets itself after a set time.

Status messages

Overview of status messages

The following section lists the messages of the main operating states of the drive which the drive passes through: when it is put into operation (see section Start sequence of the drive), when it is stopped (see section Stop sequence), or when a fault condition has occurred. The messages are sent to the higher-level control system and are displayed on the CDP control panel of the drive.



For information on other status messages, such as particular fault status messages, see the status words of the drive in Appendix M - Signal and parameter table, located on the CD.

Not ready on

NotReadyOn means that the DC link cannot be charged and the drive cannot be connected to the main power supply, i.e. the MV switchgear cannot be closed. This status message is displayed, for example, when the doors of medium voltage compartments are still open, the grounding switch of the drive is in the grounded position, or the motor starter of the fan unit is switched off, etc.



See Appendix N - Troubleshooting guide, located on the CD, for further information.

Ready on

This status message signals that the drive is healthy and ready for the ON command. The ON command initiates charging of the DC link capacitors and closing of the MV switchgear of the drive. Depending on the control place, the command can either be sent from the higher-level control system to the drive or be initiated by pressing the SUPPLY ON pushbutton on the control compartment door.

Charging

The status message ReadyOn changes to Charging when the DC link capacitors of the drive are being charged.

Ready run

The message ReadyRun tells the operator that the drive is energized and ready for operation. As soon as the start command is initiated, the motor is magnetized and the drive starts to modulate.

Ready ref

When the drive is in ReadyRef state, it is running and operating according to the set speed or torque reference value. When in remote control mode, the reference value is set at the higher-level control system. When in local control mode, the value is entered into the CDP control panel.

Stopping

Stopping indicates that the drive has received a stop command and that a stop ramp, stop torque or coast stop has been initiated. The stopping mode depends on the setting of parameter 21.02, STOP FUNCTION. The status indication changes to ReadyRun when the zero speed threshold is reached.

When a start command is given while the drive is stopping, the drive resumes operation and the status indication changes to ReadyRef again.

Tripped

This status message indicates that a fault condition has occurred that requires a shutdown of the drive. The status message always alternates with the specific fault message. The type of shutdown depends on the fault class that the fault condition is assigned to in the drive software.

—
97
Start sequence
of the drive

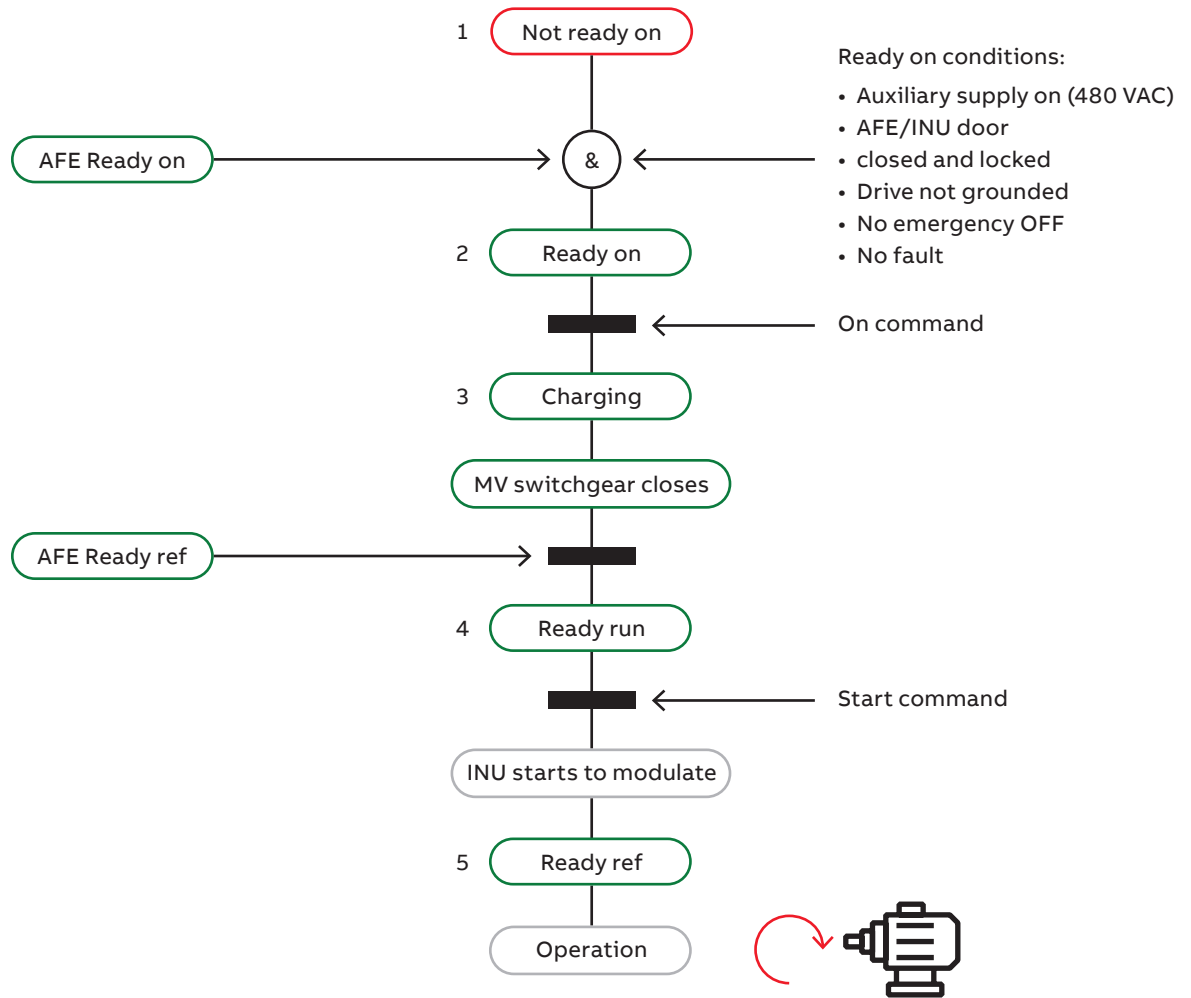

97
Stop sequence

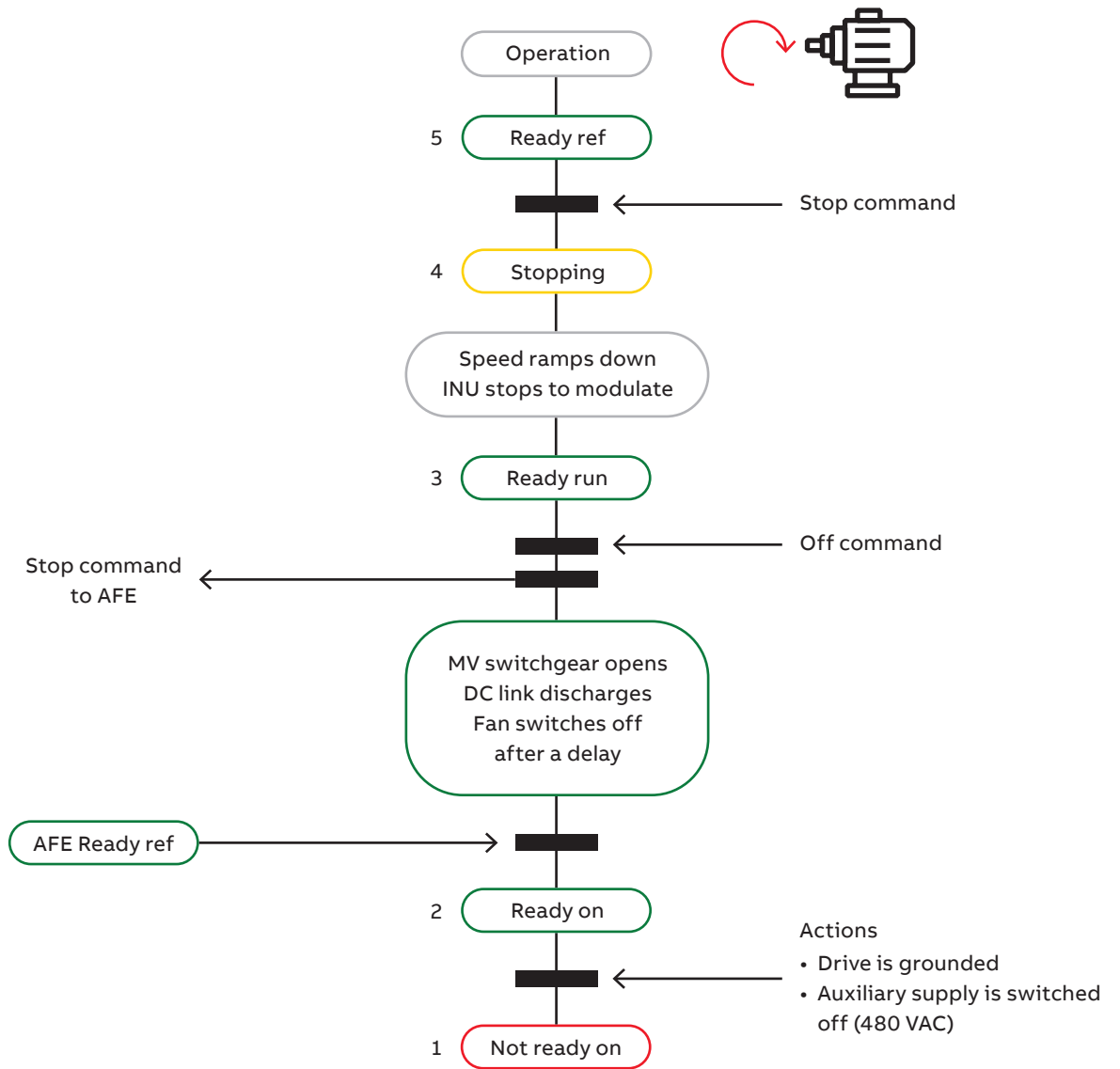

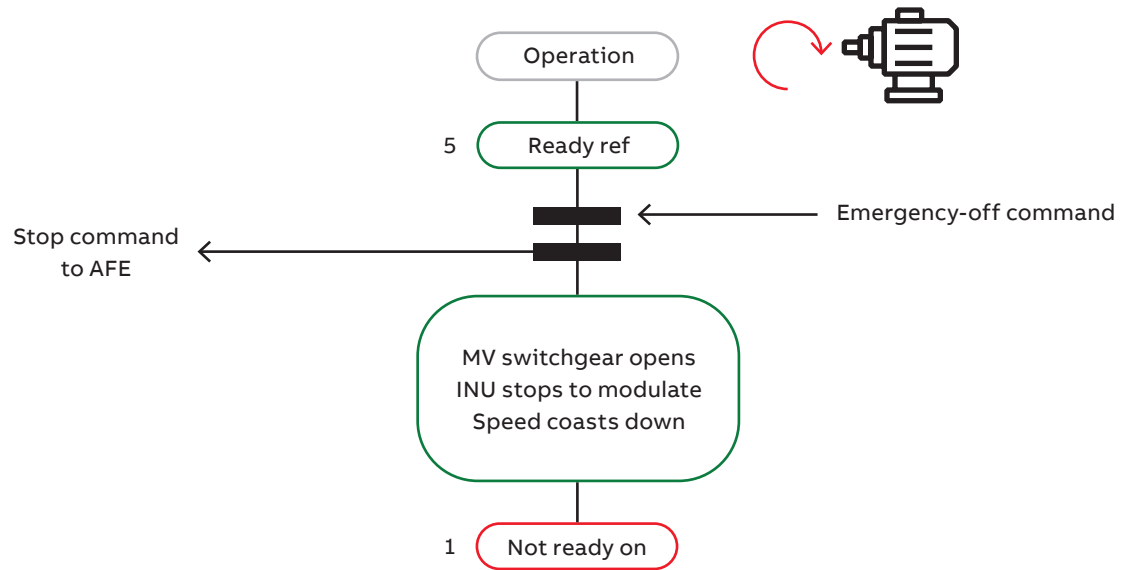

Note: For the sake of simplicity, the flow diagrams of the AFE were omitted in the preceding diagrams.

Starting the drive system

ABB recommends you have the following documents at hand when starting the drive system for the first time after commissioning:



- Appendix E - Wiring diagrams, located on the CD, to identify the circuit breakers to be switched on
- Chapter CDP control panel for information on functions and features of the CDP control panel
- Chapter Power electronics and cabinet features, section Doors and door locks, for information on the door safety switch

Checks before starting the drive system

When the drive system is put into service after it has been commissioned or after it has been taken out of service for a longer period:

- Check that no tools or foreign objects are left inside the cabinet
- Check that all auxiliary power supplies from external sources are switched on
- Check that all internal circuit breakers of the drive are closed
- Check that all covers are mounted and the doors are closed and locked



DANGER: Hazardous voltage!

All covers must be screwed in place to prevent unintentional contact with energized components. Check that the grounding switch is in ungrounded position

- Check that the MV switchgear is in operating position
- Check that there is no active run interlock
- For drives with the integral input contactor disconnect option installed, move the disconnect handle to the ON position. Refer to Appendix P for detailed information

Starting the drive system from remote

When the drive system is operated from remote through a higher-level control system or an operator control desk, follow the instructions in the appropriate manuals.

Starting the drive system locally



Note: The motor is controlled by the INU of the drive. For this reason, the CDP control panel must be connected to the INU to be able to start the drive system locally. The CDP control panel is only connected to the AFE if it is required to view status and fault messages of the AFE.

When the drive system is running, the CDP control panel can be connected intermittently without interrupting the operation of the drive.

However, to stop the drive system, the CDP control panel must be connected to the INU. Switching the CDP control panel from the INU to the AFE and back is done with the drive selection mode.

See section Drive selection mode for further information.

Procedure for starting locally

1. Check that the CDP control panel is connected to the INU.
2. Set the CDP control panel to LOCAL mode.

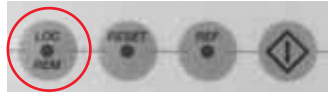

3. Check that no alarm or fault messages are displayed on the CDP control panel.

When a fault message is displayed on the CDP control panel, reset the fault.



If a fault cannot be reset, it must be rectified by the responsible personnel.

See Chapter Troubleshooting and maintenance, Troubleshooting for further information.

When no alarms and faults are present and the drive is ready, the CDP control panel displays ReadyOn.



4. Press the SUPPLY ON pushbutton on the control compartment door to charge the DC link. The pushbutton flashes during charging.

The status line of the CDP control panel alternates between Charging and AuxiliaryOn.

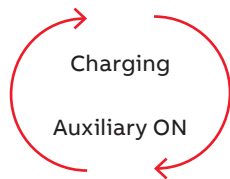

After charging is finished:

- The MV switchgear closes automatically
 - The SUPPLY ON pushbutton lights up steady
 - The AFE starts to modulate
- If the CDP control panel was switched to the AFE, you will see the message Modulating, and then after a short instant, the message ReadyRef in the status line of the display

When the AFE is in ReadyRef state, the state of the INU changes to ReadyRun and the motor can be started.

See Flow diagram in section Start sequence of the drive.



5. Enter the setpoint.

See section Entering a setpoint for procedure.



6. Start the motor.

Press the start key on the CDP control panel.

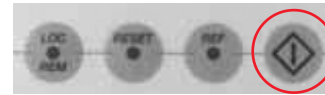

After the motor has been magnetized, the motor speed ramps up to the setpoint.

While the motor is accelerating, the run status indication on the display blinks. When the motor speed has reached the setpoint, the run status indication lights up steady.

The display shows ReadyRef to indicate that the drive system is operating.



Stopping

Press the stop key on the CDP control panel.



The motor stops according to the preset stop function and the drive stops modulating. While the motor stops, the status line of the display shows ReadyRef. The run status indication blinks during the stop sequence.



As long as the stop sequence is in progress, the drive can always be restarted by pressing the start key on the CDP control panel.

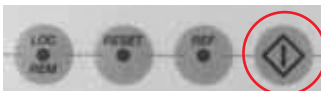

Just before the motor comes to a standstill, the CDP control panel briefly displays the message Stopping.



When the drive has stopped modulating, the CDP control panel displays ReadyRun.



De-energizing the drive



DANGER: Hazardous voltage!

Do not try to gain access to the medium voltage compartments of the drive, or the motor, as long as the drive system is energized and ungrounded.



Note: For drives with the integral input contactor disconnect option installed, refer to Appendix P for detailed information as some compartments such as TEU are still live after disconnect is opened.

Procedure for disconnecting the drive from the main power supply

1. Stop the motor as described in the previous section.

When the motor has reached zero speed, the display shows ReadyRun.



2. Press the SUPPLY OFF pushbutton to disconnect the drive from the main power supply.

The following takes place:

- The MV switchgear opens
 - The DC link discharges
- While the DC link discharges, the display shows OffSeqOn



- The SUPPLY OFF pushbutton flashes and changes to a steady light when the DC link is discharged completely
- When the DC link is discharged, the display shows ReadyOn



3. Turn the grounding switch to the grounded position when the GROUND SW RELEASED pilot light is on.

NOTICE

NOTICE: The auxiliary voltage must be applied, switched on, to operate the grounding switch.

Do not turn the grounding switch to the grounded position before the light GROUND SW RELEASED is on. Otherwise, the switch will be damaged.

The pilot light illuminates only after the fan stops. The fan runs continuously for a preset time after the main power supply has been switched off to dissipate the heat from the drive.

If the pilot light does not illuminate and there is reason to believe that the grounding circuit is malfunctioning, see Chapter Troubleshooting and maintenance, Malfunctioning grounding switch for further information.

When the grounding switch is in the grounded position, the status line of the display alternates between DCGnd NOpen, NotReadyOn, AFE NotRdy.

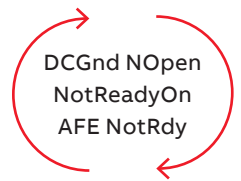

4. Rack-out, lock-out, ground and tag-out the MV switchgear.



The grounding switch connects the DC link of the drive to the PE (Protective Earth) ground bus.

If maintenance on the drive that includes the removal of phase modules is planned, the connection of grounding equipment at the appropriate locations is a must. This is to ensure that hazardous voltages are discharged and therefore cannot be fed into the drive from the main power supply or from the motor.



Note: For drives with the integral input contactor disconnect option installed, move the handle to the OFF position. The integral disconnect option does not remove medium voltage from the TEU (Terminal Entry Unit). Remove power at an upstream source before entering the TEU. Refer to Appendix P for detailed information.

Figure 99 shows an example of how the terminals of the line supply cables (1) are grounded at the PE ground bus (2) using a 4-way grounding set (3).

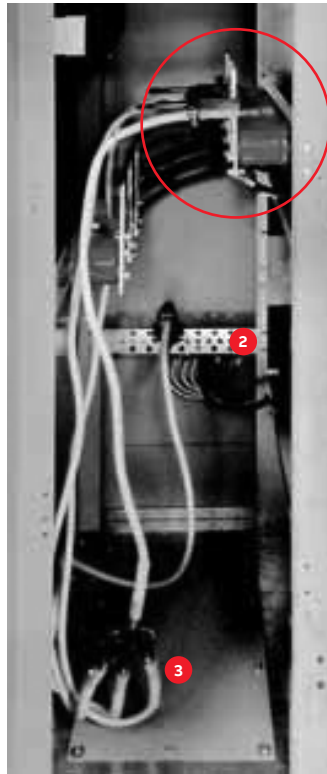

- | | |
|---|---------------------|
| 1 | Line supply cables |
| 2 | PE ground bus |
| 3 | 4-way grounding set |

- Switch off all auxiliary voltages from external sources.

The drive is safely grounded, and safe access is possible.

Emergency-off

Function

The drive is equipped with a hardwired emergency-off circuit. If an emergency situation occurs during operation, this safety feature ensures that the drive system can be disconnected without delay from the main power supply. When the emergency OFF pushbutton has been pressed while the drive is at standstill, the main power supply cannot be connected to the drive, hence the drive cannot be started up.

The emergency OFF pushbutton of the drive is part of the operator control panel (see Figure 96).



CAUTION: Pressing the emergency OFF pushbutton does not disconnect or switch off the auxiliary power supply from the drive.

Initiating an emergency shutdown

An emergency shutdown is initiated by pressing the emergency OFF pushbutton on the control compartment door or an external emergency OFF pushbutton (if present) linked to the emergency-off circuit.

When an emergency shutdown is initiated during drive operation:

- The MV switchgear opens
- The drive system coasts down
- The DC link of the drive discharges
- The status line of the CDP control panel alternates between the messages `EmergeOff`, `NotReadyOn`



Procedure for starting the drive system after an emergency shutdown

- Pull out the emergency OFF pushbutton.
- Push the CDP panel reset button.



After resetting, the status indication of the drive changes to `ReadyOn`.



Now, the main power supply can be connected to the drive again and the drive system can be started up.

CDP control panel

100
CDP control panel

Overview



Note: The panel messages and parameter settings used in this chapter are examples for illustration and may differ from the actual messages and parameter settings of your drive.

Display and keypad

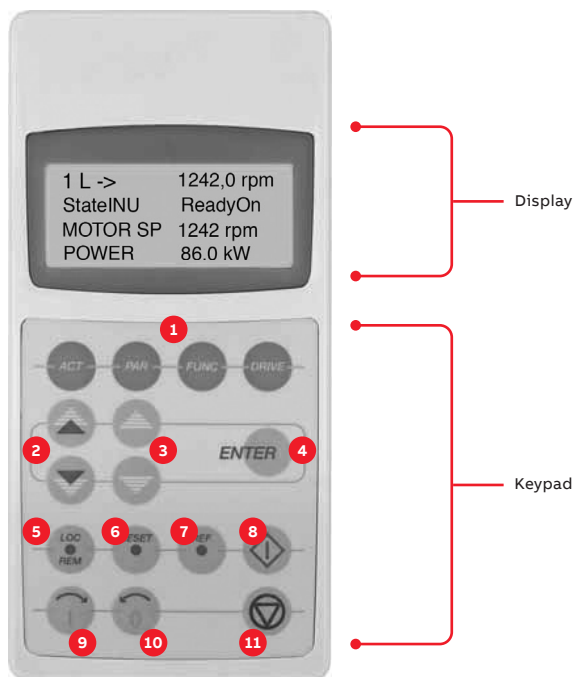

1	Mode selection keys
2	Fast navigation keys, select and/or change a value fast
3	Slow navigation keys, select and/or change a value slowly
4	Enter key, executes a procedure
5	Local/remote selection key
6	Reset key
7	Reference key
8	Start key
9	Forward key
10	Reverse key
11	Stop key

Overview of CDP control panel functions

The CDP control panel serves as the basic user interface for operating and monitoring the drive when the local operating mode has been selected.

The CDP control panel can be attached to or detached from the drive without having to switch off the auxiliary power supply first.

Using the CDP control panel it is possible to:

- Enter start-up data
- Control the drive with a reference value and start, stop and direction commands
- Display actual values (three values can be read simultaneously)
- Display and adjust parameters
- Display information on the most recent 64 fault events

Overview of CDP control panel modes

The CDP control panel provides the following modes:

- Identification mode
See section Identification mode for further information
- Actual signal display mode
See section Actual signal display mode for further information
- Parameter mode, selected by the PAR key
See section Parameter mode for further information
- Function mode, selected by the FUNC key
See section Function mode for further information
- Drive selection mode, selected by the DRIVE key
See section Drive selection mode for further information

Identification mode

When the power supply is switched on, or the CDP control panel is connected to the drive and the auxiliary voltage has been switched on already, the identification display appears showing the CDP control panel version and then the ID-number of the drive. When the CDP control panel is initialized, the display changes as follows:

Display when initialized



After 2-3 seconds, information on drive (1, 2), the application software in use (3), and the drive identification (4) is displayed.

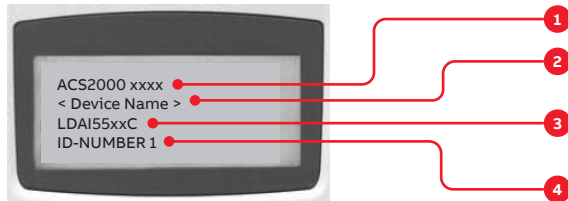

After another few seconds



After another few seconds, the display changes to the actual signal display mode. The status line of the display alternates between DCGndNopen, NotReadyOn.



Actual signal display mode

Overview

Two kinds of displays can be selected in the actual signal display mode:

- Actual signal display
- Fault history display

The actual signal display appears first when the actual signal display mode has been selected. However, when the drive is in a fault condition, the fault display will be shown instead.

The actual signal display is used to monitor the drive without interfering in its operation. Three selectable actual values are shown continuously on the display.

The CDP control panel will automatically return to the actual signal display mode from other modes within one minute when no keys are pressed (exceptions: status display and common reference display when in drive selection and fault display mode).

Actual values

- Group 01 - Measured or calculated motor values
- Group 02 - Measured or calculated drive values
- Group 03 - Reference values
- Group 04 - Status signals of IOEC I/O system
- Group 05 - Communication link and MV switchgear status signals
- Group 06 - Software version, drive and motor nominal values
- Group 07 - Control words
- Group 08 - Status words
- Group 09 - Fault and alarm words



See Appendix M - Signal and parameter table, located on the CD, for the complete list of selectable actual signals.

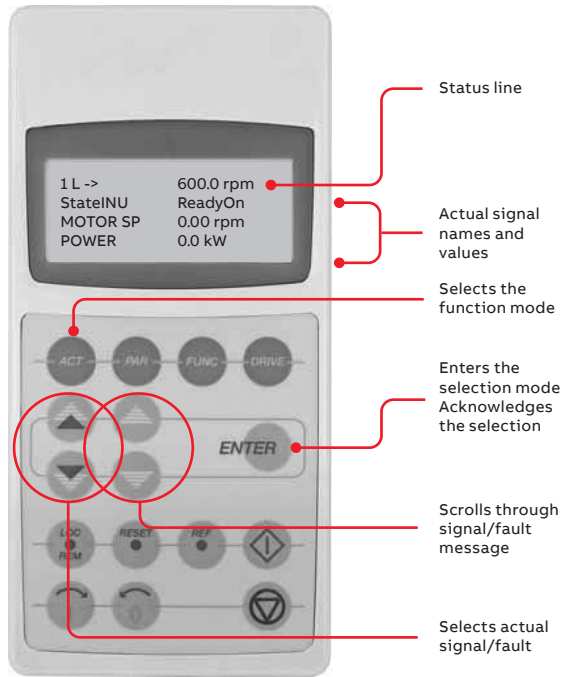

Fault memory

The fault memory includes information on the 64 most recent fault events that occurred in the drive. The name of the fault and the actual time are displayed. The procedure for selecting and clearing the fault history is described in section Displaying and resetting an active fault.

When a fault or warning is generated in the drive, the message will be displayed immediately, except when in drive selection mode.

Changing from the fault display mode to other display modes is possible without resetting the fault first. When no keys are pressed, the fault or warning text is displayed as long as the fault is pending.

Selecting the actual signal display

The actual signal display mode is selected by pressing the ACT key.



Toggle between actual signal display and fault history

When in actual signal display mode, the fast up/down keys allow the user to toggle between actual signal display and fault history display.



Displaying three actual signals

1. To display the full name of three actual signals, press and hold the ACT key.



2. To return to the actual signal display, release the ACT key.

Selecting actual signals

1. To select the actual signal display, press the ACT key.



2. To select a row where the actual signal is to be displayed, press the corresponding slow navigation key. A blinking cursor indicates the selected row.



3. To enter the actual signal selection function, press the ENTER key.



7. To cancel the selection and keep the original selection, press any of the mode keys. The selected CDP control panel mode is entered.



4. To select a parameter group, press the corresponding fast navigation key.



- Displaying a fault and resetting the fault history**
1. To enter the actual signal display mode, press the ACT key.



5. To select an actual signal, press the corresponding slow navigation key.



2. To enter the fault history display, press either of the fast navigation keys.



6. To accept the selection and to return to the actual signal display mode, press the ENTER key.



3. To select the previous or next fault, press the corresponding slow navigation key. The up key selects the previous, the down key the next fault.



4. To clear the fault history, press the RESET key.



5. To return to the actual signal display mode, press either of the fast navigation keys.



Displaying and resetting an active fault

1. To display an active fault, press the ACT key.



2. To reset the fault, press the RESET key.



Parameter mode

Overview

Parameters allow the drive to be configured and set up specifically for an application. Parameters are organized in functional groups. All control functions are represented by a parameter group and can be activated and set up individually in the parameter mode.

- Group 07 - Control words
- Group 08 - Status words
- Group 09 - Fault & alarm words
- Group 11 - Start/stop/direction/MV switchgear control
- Group 12 - Reference select
- Group 16 - System control inputs
- Group 17 - DC link control
- Group 18 - Utility
- Group 19 - Data storage
- Group 20 - Limits
- Group 21 - Start/stop/process stop
- Group 22 - Ramp functions
- Group 23 - Speed reference

- 21.01 - Start function
- 21.02 - Stop function
- 21.03 - Off1 stop mode
- 21.04 - Process stop selection
- 21.05 - Process stop signal
- 21.06 - Process stop MV switchgear control
-
-
-
- 21.07 - Process stop mode ...
- 21.17 - MV switchgear closing time limit
- 21.18 - MV switchgear opening time limit
- 21.19 - MV switchgear available signal

 See Appendix M - Signal and parameter table, located on the CD, for further information on the parameters, their settings and functions.

NOTICE

NOTICE: Parameters must only be set by qualified personnel. Do not change any parameter if the meaning of the parameter and the effects of the change are not fully understood. Running the drive system with incorrect data can result in improper operation, reduction of control accuracy and damage of equipment.

When the parameter mode is entered for the first time after the auxiliary voltage of the drive has been switched on, the display will show the first parameter of parameter group 11. After that, the previously selected parameter is shown when the parameter mode is selected.

Some parameter values cannot be changed while the drive is running. If this is attempted, the following warning will be displayed:

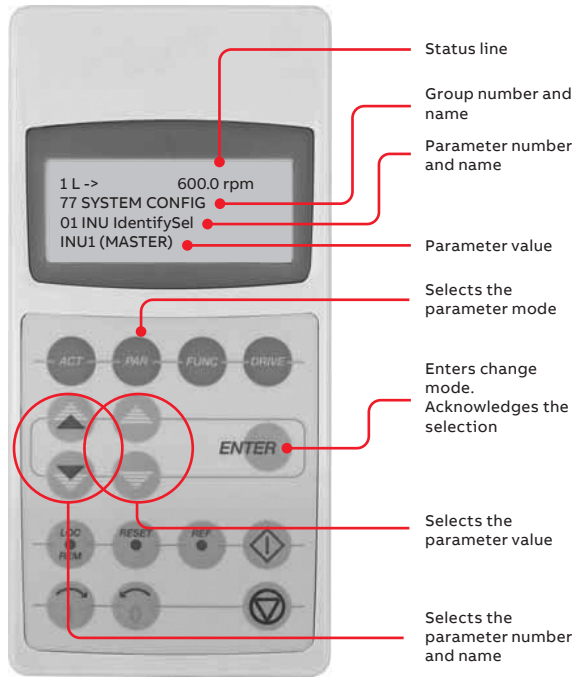

Setting parameters procedure

1. To enter the parameter mode, press the PAR key.



2. To select a different group, press the corresponding fast navigation key.



3. To select a parameter, press the corresponding slow navigation key.



4. To enter the parameter setting function, press the ENTER key.



5. To change the parameter value, press:
- The corresponding slow navigation key for numbers and text
 - The corresponding fast navigation key for numbers only



6. To accept the selection and to return to the actual signal display mode, press the ENTER key.



7. To cancel the setting and keep the original selection, press any of the mode keys. The selected CDP control panel mode is entered.



Parameter lock

Unauthorized parameter entry can be prevented by activating the ParameterLock function in parameter group 16 SYSTEM CTRL INPUTS.

The ParameterLock is activated by setting parameters 16.02 and 16.03 accordingly.

Activating the ParameterLock

1. Select parameter 16.02 PARAMETER LOCK.
2. Set parameter 16.02 to LOCKED.
3. Save the setting and exit the parameter mode.

Opening the ParameterLock

1. Select parameter 16.03 PASSCODE.
2. Set the correct pass code.
3. Save the setting and exit the parameter mode.



See Appendix M - Signal and parameter table, located on the CD, for further information.

Function mode

Overview

The function mode is used to set the display contrast.

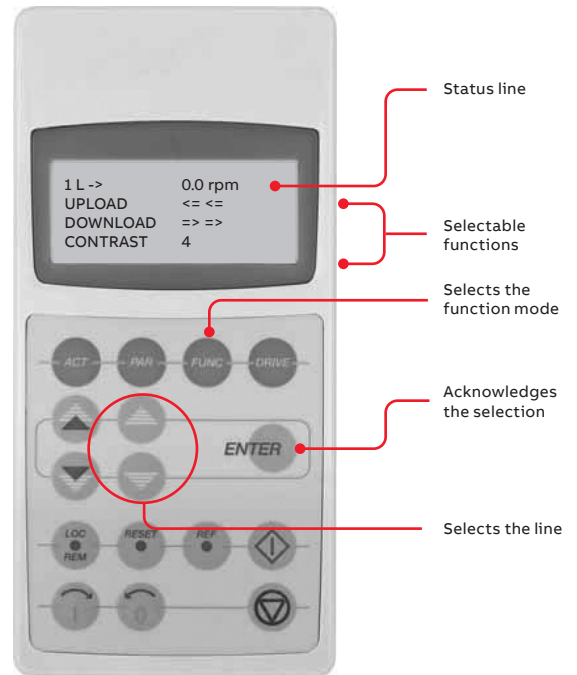

Setting functions procedure

1. To enter the function mode, press the FUNC key.



2. To select a function (a blinking cursor indicates the selected function), press the corresponding slow navigation key.



6. To cancel the setting and keep the original selection, press any of the mode keys. The selected CDP control panel mode is entered.



3. To enter the contrast setting function, press the ENTER key.



4. To change the contrast value, press the corresponding slow navigation key.



5. To accept the selection and to return to the actual signal display mode, press the ENTER key.



Drive selection mode

Overview

The drive selection mode is used to connect the CDP control panel to either the AMC (Application and Motor Controller) circuit board of the AFE (Active Front End) or the INU (Inverter Unit) of the drive.



Note: In this context, the AMC circuit board of the AFE and INU is referred to as a drive that is identified in the control system by its ID number:

- ID number of INU: 1
- ID number of AFE: 2

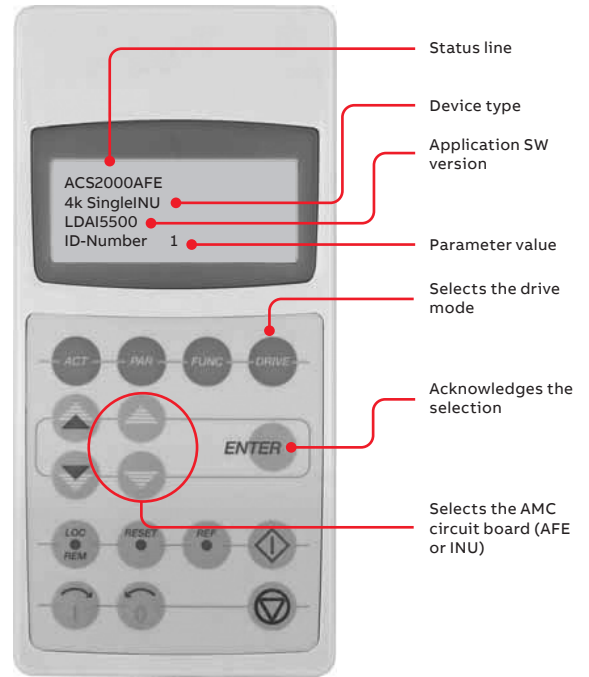

—
105
LOC/REM key

Drive selection procedure



Note: It is assumed in the following example that the CDP control panel is connected to the INU.

1. To enter the drive mode, press the DRIVE key.



2. To connect the CDP control panel to the AFE, press either of the slow navigation keys to select the ID number of the AFE.



If none of the keys is pressed, the display will automatically return to the actual signal display mode after a while.

If the ID number of the AFE or INU is accidentally changed (e.g. to 3) and the ENTER key has been pressed, the new number will be saved in the memory. The display will still show the old number. Only when the auxiliary voltage has been switched off and on again, will the new number be shown on the display.

If the ID number is accidentally changed, simply change the ID number back and press the ENTER key. The ID number will be restored the next time the auxiliary power is switched off and on.



Note: DO NOT select LOCAL by pressing the LOC / REM key when the CDP control panel is connected to the AFE. If the drive is in operation, the AFE will stop modulating and the drive will shut down. If the drive is stopped and the CDP control panel is set to LOCAL, the drive cannot be started up.



—
105

Operational commands

Local remote control location

The local/remote feature of the CDP control panel allows the operator to select the control location of the drive:

- Local control
- Remote control

The control location is selected by pressing the LOC / REM key on the CDP control panel.



Local control

When the CDP control panel is switched to local, operation via the pushbuttons on the control compartment door and the CDP control panel is possible. Control commands from remote have no effect. Local can only be selected when the drive has been stopped and no remote run command is active. Switching from local to remote while the drive is running will stop the drive.

Remote control

When the CDP control panel is switched to remote, the pushbuttons on the control compartment door and the operational keys of the CDP control panel are disabled. Operational commands and reference values from a remote control station are transmitted via fieldbus or remote I/O to the drive. Switching from remote to local while the drive is running is not possible.

Selecting local and remote

- To select local control, press the LOC / REM key. The local control location is indicated by the letter L.



Local control location

- To select remote control, press the LOC / REM key. The remote control location is indicated by a blank (see arrow).



Remote control location

- The keypad can also be used as a remote control place. In this case, the parameters 11.01, 11.02, 12.03 or 12.06 must be set to KEYPAD. In this setup the remote control location is indicated by the letter R. The START/STOP commands and the reference value can be set from the CDP control panel.



Remote control location

Enable lock function

The lock function is disabled if the parameter 16.04 is set to 1 (= OPEN). Switching from local to remote and vice versa is possible.

Disable lock function

The lock function is enabled if the parameter 16.04 is set to 2 (= LOCKED). In this case, local cannot be selected on the CDP control panel. However, the CDP control panel or the DriveWindow PC will remain in local mode (if they were already in local mode when the parameter was set to locked) until the CDP control panel is switched to remote.

The letter L remains on the display until the LOC / REM key is pressed.

Setting the direction of rotation

The direction of rotation is selected using the forward (I) or reverse (O) key of the CDP control panel. Both keys can be used if the CDP control panel is in local mode. The function is released with parameter 11.03 DIRECTION (REQUEST).



Forward rotation



Reverse rotation

Locking local or remote control mode

Accidental switching from remote control to local control can be prevented with the lock function of parameter 16.04.

The parameter 16.04 LOCAL LOCK locks or unlocks the LOC / REM key of the CDP control panel and determines the control place where the lock function is activated (CDP control panel or remote control location).

The arrow on the display indicates the direction:

- When the motor is running, the arrow indicates the actual direction of rotation
- When the motor is not running, the arrow indicates the preselected direction of rotation

When the direction of rotation is changed while the motor is running, the speed will automatically ramp to zero and the motor will accelerate in the opposite direction to the preset speed. The direction of the arrow on the display changes to the new direction when the motor has reached zero speed.

Entering a setpoint

A setpoint can be changed at any time if the CDP control panel has been set to local.

1. To enter a control panel mode displaying the status row, press a mode key.



Run status indication

The run status indication on the display (see arrows) changes depending on the state the INU is in:

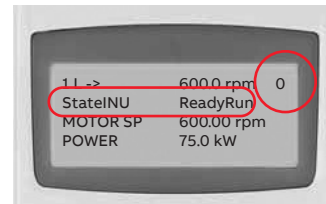
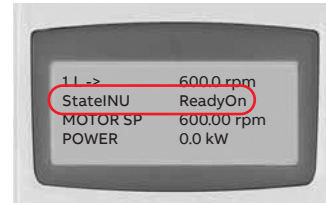

2. To enter the setpoint setting function, press the REF key.

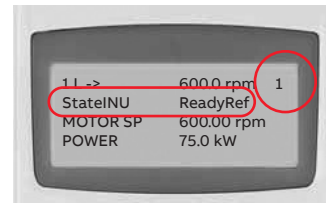

3. To change the setpoint, press either the corresponding fast or slow navigation key.



4. To exit the setpoint setting mode, press any of the mode keys.



Troubleshooting and maintenance

General information

Required qualification

Maintenance and parts replacement on the drive must be performed only by qualified personnel, and in compliance with local regulations.

Warranty period

During the warranty period of the drive, any repair work must be performed exclusively by ABB service personnel. After the warranty period, repair work may only be performed by qualified personnel.

Training courses

ABB offers maintenance and service training courses. Customer staff having successfully attended such courses, will be certified to do maintenance and repair work on the drive. To maintain safe and reliable operation of the drive, ABB recommends taking out a service contract with the ABB service organization.

For more information contact the ABB service organization. See section General information on manual and equipment for contact information.

Maintenance schedule



ABB strongly recommends that all maintenance tasks listed in Appendix A - ACS2000 maintenance schedule, located on the CD, and applicable service instructions are performed on time and at the stated intervals.

Log book

ABB recommends recording all troubleshooting and maintenance work in a log book including:

- Date and time
- Detailed description

Spare parts



Only use spare parts recommended and approved by ABB. See Appendix F - Spare Parts list, located on the CD, for information on types and identification codes.

Further information

Supplementary information on troubleshooting and maintenance can be obtained from the following manuals:

- Service and maintenance manual with instructions on checking and replacing semiconductors and other components
- Appendix M - Signal and parameter table, located on the CD
- Appendix N - Troubleshooting guide, located on the CD

The document supplements the Signal and parameter table and provides explanations of alarm and fault messages, associated parameters and I/Os, and hints for corrective actions.

Identifying electrical equipment

Device identification

All electrical devices are identified by an identification number label near the part and in the wiring diagram using the same part number (e.g. - A1461, see Figure 106).

—
106
Device identification
—
107
Example alarm or
fault message

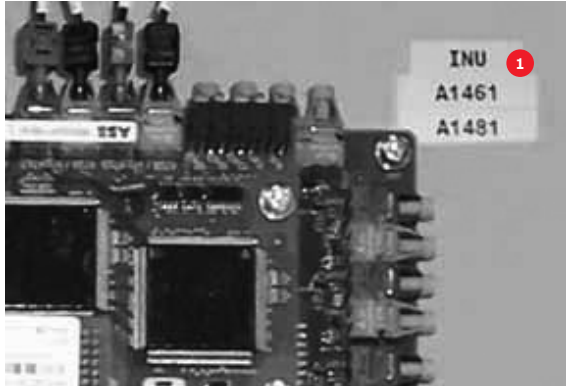

- | | |
|---|-----------------------------------------|
| 1 | Identification number label near part |
| 2 | Identification number in wiring diagram |
| 3 | Identification number breakdown |

—
106

Device identification

The way the identification number is built directly corresponds to the wiring diagram as can be seen in Figure 106. The letter A represents the kind of part we have, an assembly, the next three digits are the page number the part is located on, page 146, and the last digit, 1, means that our part is the first assembly on the page. This identification label number is the key to track electrical devices throughout the drive and in ABB documentation.

 Technical details and part numbers of the components are provided in Appendix F - Spare Parts list, located on the CD.

Cables and wires

Cables and wires in the drive are equipped with marker sleeves which carry the same identification number as in the wiring diagrams.

Understanding wiring diagrams

 Item designation and cross-reference conventions are defined in Appendix E - Wiring diagrams, located on the CD.

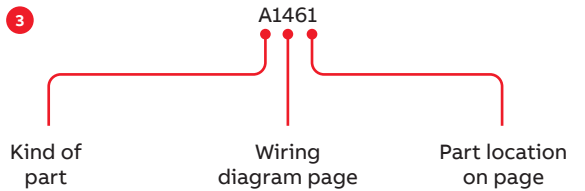
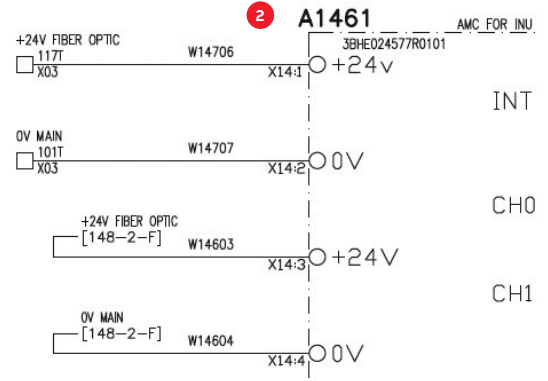

Troubleshooting

Alarm and fault indications

When a malfunction occurs in the drive or in the equipment monitored by the drive (e.g. MV [Medium Voltage] switchgear, transformer, cooling system), the CDP (Control Display Panel) presents a corresponding alarm or fault message and the alarm/fault pilot light on the control compartment door lights up:

- Alarm: flashing light
- Fault: permanent light



- | | |
|---|-------------------|
| 1 | CDP fault display |
| 2 | Fault light |

—
107

The display message can be saved and viewed in the fault log of the drive when a PC with the DriveWindow, DriveDebug or DriveMonitor™ tool is connected to the drive. The fault log can also be called up on the CDP control panel.

Error message levels

Two error message levels are used in the drive:

Alarm/warning

An alarm does not shut down the drive. However, a persisting alarm condition can often lead to a fault if the condition causing the alarm is not corrected. An alarm cannot be reset manually. The alarm message will be deleted from the display as soon as the alarm condition has been corrected.

Fault

A fault always shuts down the drive. The type of shutdown depends on the origin of the fault.

Depending on the type of fault, the MV switchgear is opened by the drive or stays closed:

- Class 1 faults (FC 1) open the MV switchgear
- Class 2 faults (FC 2) do not open the MV switchgear

Since the MV switchgear is controlled and monitored entirely by the drive, no external opening command must be given to the MV switchgear when a fault condition occurs.

In general, a fault condition must be corrected and the fault be manually reset before the drive can be started again.

Alarm/fault handling

In the event of an alarm or a fault, a specific message is saved in the fault log of the drive. Information on the 64 most recent fault and alarm events are saved.

The faults are entered into the fault buffer as they occur and are numbered; the last fault entered always has number 1 assigned to it and the first fault always has the highest number in the fault buffer.

Information of the fault classification (e.g. FC 1 or FC 2) is also saved when the first fault of the fault class is active. Date and time stamps facilitate fault tracing, especially when a fault leads to several subsequent faults.

Example:

1. +Fault AMC: Fault Class 2
2011-01-08 16:58:24.3770
2. +Fault PPCS Communication
2011-01-08 16:58:24.3760
3. +Fault AMC: Fault Class 1
2011-01-08 16:56:02.1170
4. +Fault DC Undervoltage
2011-01-08 16:56:02.1170

In the above example:

- 4. +Fault DC Undervoltage is the reason for the failure of the drive, as it occurred first
- The message 3. +Fault AMC: Fault Class 1 classifies the fault
- The message 2. +Fault PPCS Communication occurred 2 min 22 seconds later than the first fault due to another fault in the drive
- The message 1. +Fault AMC: Fault Class 2 informs about the pending fault class



For further information on alarms and faults, see:

- Appendix M - Signal and parameter table, located on the CD
- Appendix N - Troubleshooting guide, located on the CD

Standard troubleshooting procedure

Recommended procedure if a malfunction shuts down the drive:

1. Do not switch off the auxiliary voltage or try to reset a fault message before all essential information at the time of the occurrence of the fault condition has been saved.
2. Call up the Fault History Display on the CDP control panel.

See Chapter CDP control panel if further information is required.

Do not clear the fault buffer of the drive now!

3. Identify the fault and make a log book entry.



Note the fault message displayed on the CDP control panel and look up the fault message in Appendix N - Troubleshooting guide, located on the CD, for further information.

4. Save the content of the data log when a PC is available that has the DriveWindow tool installed.

The data log provides useful information (e.g. waveforms of voltage, current, torque, etc.) for efficient troubleshooting.

5. Try to rectify the fault, following the instructions in Appendix N - Troubleshooting guide, located on the CD.
6. Contact ABB service if a fault cannot be rectified.

When contacting ABB, have the following data available about the fault occurrence:

- Operating, ambient and load conditions
- Unusual events

After the fault has been rectified, start the drive as described in Chapter Local operation.

Malfunctioning grounding switch

CAUTION

CAUTION: If the control circuit of the grounding switch malfunctions, it is possible that the grounding switch is closed while the DC link is still charged, and because of that, the DC capacitors are short-circuited. The short-circuit will manifest itself in a loud bang. To prevent temporary minor hearing impairment, follow the instructions below.

When the DC link of the drive has been de-energized, the GROUND SW RELEASED pilot light illuminates to indicate that the grounding switch is released and can be turned to the grounded position. If the release pilot light does not illuminate and there is reason to assume that the grounding circuit is malfunctioning, proceed as follows:

1. Do not try with force to turn the grounding switch in any direction.

The handle and/or the switch could be damaged or broken if force is used.

2. Verify that the MV switchgear is in the open position.
3. Check the drive status on the CDP control panel.

The message ReadyOn is displayed when the DC link of the drive has been discharged.



- 4 Verify that the DC link has been discharged.

The discharging level can be viewed in parameter 2.01 DC VOLTAGE. The value should be below 50 V.

5. Check if there are any alarm and fault messages on the display.

If there are any, look up the messages in Appendix N - Troubleshooting guide, located on the CD, and follow the instructions.

6. Try to rectify the reason for the alarms and faults, and then press the reset key on the CDP control panel.



7. Contact ABB service if the cause for the malfunctioning grounding switch cannot be rectified.

See section General information on manual and equipment for contact information.

LEDs and switches on PCBs and IOEC I/O devices

The following section provides an overview on the meaning of LEDs and switches of the main circuit boards and IOEC I/O devices. The LEDs presented in the following section can be checked easily while the auxiliary voltage is switched on without having to remove covers first. The LEDs provide information on the status of the devices and can be used for diagnostic purposes.

- 108
AMC circuit board
- 109
IOEC I/O module

AMC circuit board

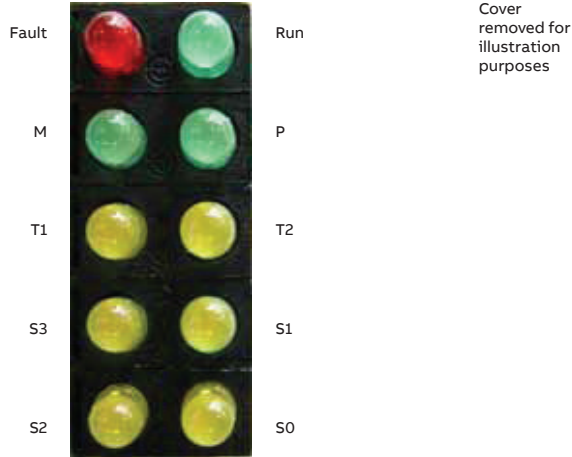
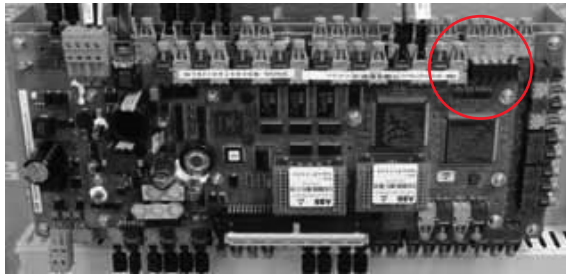

— 108

Table 26: Function of LEDs on the AMC circuit board

LED	Color	Function
F	red	Fault, not used (ON when booting)
R	green	Run, always OFF
M	green	Not used (ON when booting)
P	green	Supply OK
T1	yellow	ON = receiving data on DDCS channel 0
T2	yellow	ON = receiving data on DDCS channel 3
S3	yellow	Always OFF
S1	yellow	Always OFF
S2	yellow	Always OFF
S0	yellow	Always OFF

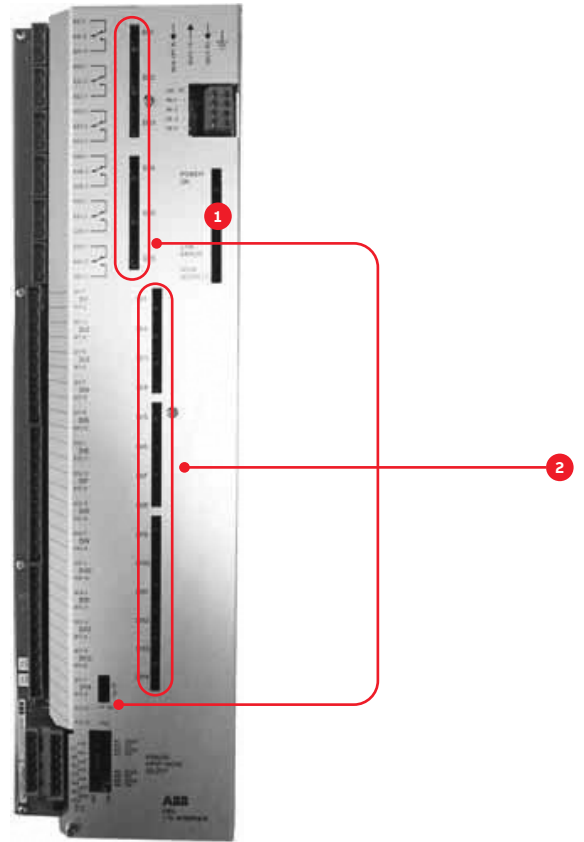

1	Link error light
2	LEDs

— 109

The link error light (1 in Figure 109) is either on or off. It is on only when there is a problem with the fiber optics.

All other LEDs (2 in Figure 109) are on if energized.

IOEC I/O node address

Each IOEC module has a unique cluster address that identifies the module in the software and links it to a parameter.



See Appendix E - Wiring diagrams, located on the CD, for information on IOEC switch settings.

Fieldbus communication adapters

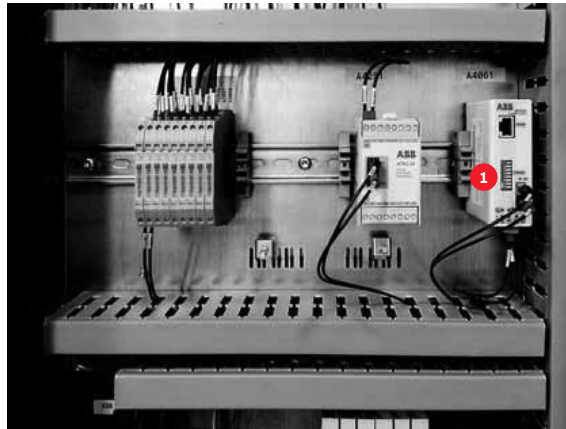

1 Fieldbus communication adapter

The drive can be equipped with one of the following fieldbus adapters.

Table 27: Fieldbus adapters

Fieldbus	Option code
Modbus	+FAMMO
Ethernet	+FAMEO
Profibus DP/FMS	+FAMPO
Anybus DeviceNet Module	+FAMAD
Anybus EtherNet IP Module	+FAMAE
Anybus ControlNet Module	+FAMAC



See Appendix E - Wiring diagrams, located on the CD, to identify the adapter type installed in your drive.



See Appendix B - Fieldbus adapter manuals, located on the CD, for detailed information.

Maintenance

Overview of maintenance and service tasks

- Visual checks on the drive
See section Visual checks on the drive
- Checking wire and cable connections
See section Checking wire and cable connections
- Checking and replacing filter mats
See section Checking and replacing filter mats
- Replacing a phase module
See section Replacing a phase module



See Service and maintenance manual for information on maintenance and service work other than described in this manual.

Safety



DANGER: Hazardous voltages!

Follow proper lock out and tag out safety procedures. Failure to do so may result in death or serious injury.

Before starting with maintenance, make sure that:

- Personal protective equipment is provided and used when required
- Everyone involved is informed
- The main power supply is switched off, locked out and tagged out
- Rack out the MV switchgear, lock it in open position, and tag it
- Safety ground connections are in place.
- The auxiliary power supply is switched off, locked out and tagged out
- The voltage is 0 V at the supply terminals when checked using a multimeter
- The MV switchgear control power supply is switched off and locked out
- If an optional 120 V control power or space heater is installed, these supplies are switched off and locked out

Before energizing the drive again, make sure that:

- All foreign objects are removed from the drive
- All internal and external covers are securely fastened and all doors are closed, locked and / or bolted



DANGER: Hazardous voltages!

When maintenance on the drive is carried out that includes the removal of phase modules, the connection of grounding equipment at the appropriate locations is a must. The grounding equipment ensures that hazardous voltages cannot be fed into the drive from the main power supply or from the motor.

NOTICE

NOTICE: When working on the drive, ensure that foreign matter cannot enter the cabinet. Close the doors and cover openings completely when work is discontinued. Any foreign matter which accidentally dropped into the cabinet must be retrieved. Metallic dust, in particular, could cause malfunction and damage when the drive is energized.

—
111
Frame 1 Front
service access

—
112
Frame 2 Front
service access

—
113
Frame 1 Rear
service access

Service access



CAUTION: High temperature!

Components inside the drive can be hot. Particularly the temperature of the resistor assembly is very high when the drive has been in operation.

Before taking off any of the covers on the back of the cabinet, wait until the fan has stopped. The fan runs continuously for a preset time after the main power supply has been switched off to cool down the resistors and dissipate the heat from the drive.



- 1 TEU (Terminal Entry Unit)
- 2 Filter compartment

—
112

The ACS2000 is designed to allow all service access from the front of the drive. The bolted plates can be removed to access the terminal entry unit (1), and the filter compartment (2).

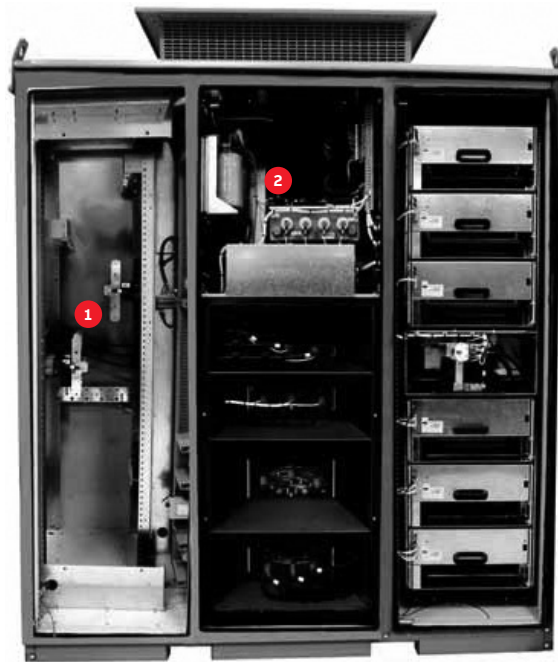

- 1 TEU (Terminal Entry Unit)
- 2 Filter compartment

—
111

Rear service access

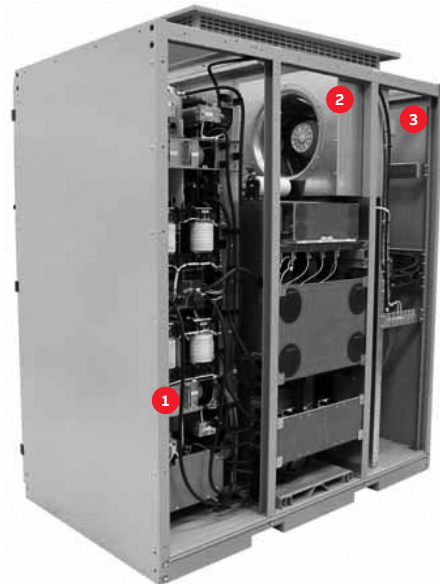

- 1 AFE/INU compartment
- 2 Filter compartment
- 3 TEU (Terminal Entry Unit)

—
113

—
114
Frame 2 Rear
service access

—
115
Frame 3 Rear
service access

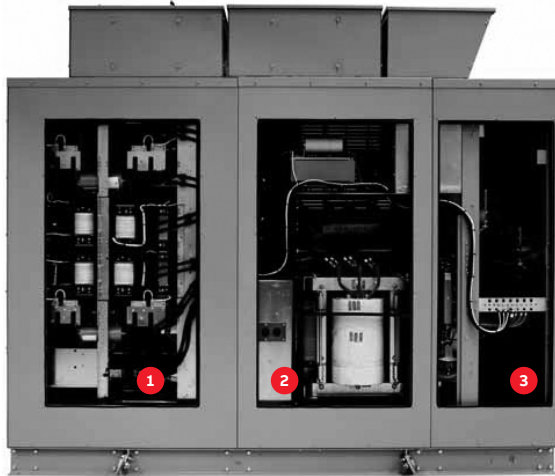

- | | |
|---|---------------------------|
| 1 | AFE/INU compartment |
| 2 | Filter compartment |
| 3 | TEU (Terminal Entry Unit) |

—
114



- | | |
|---|---------------------------|
| 1 | AFE/INU compartment |
| 2 | Filter compartment |
| 3 | TEU (Terminal Entry Unit) |

—
115

The cabinet is also equipped with service covers to facilitate easy access to components from the rear of the cabinet. The covers enable rear access to the AFE/INU (Active Front End/INverter Unit) compartment (1), the filter compartment (2) and the TEU (Terminal Entry Unit) (3).

Visual checks on the drive



Check the drive and its immediate vicinity visually at the intervals stated in Appendix A - ACS2000 maintenance schedule, located on the CD, and pay attention to the following items:

- Condensation inside the drive
- Permitted range of ambient air temperature and humidity of the drive



See the drive Rating label located on the inside of the control compartment door for information on permitted air temperature range.

- Dust built-up inside the drive room and inside the drive
- Signs for overheated components, wires, cables or busbars
- Corrosion on circuit boards, connectors or busbars
- Appropriate fastening of cables and wires and connections of cable shields
See Chapter Electrical installation if further information is required

- Integrity of cable insulation
- The outer cable sheath must not be damaged
- Correct type of signal and power cables



See Appendix H - Power Cable Specifications, located on the CD, for applicable field power cable reference.

Cleaning

Dust on electrical components and wiring can cause malfunction and damage the components. Dust and moisture can build up in loose connections and cause loss of low-level signals.

For these reasons, the cabinet should be checked regularly and cleaned if necessary.

When cleaning the drive cabinet, mind the following:

- Cover equipment or assemblies to prevent dirt from falling into it
- The drive contains components which are sensitive to electrostatic discharge. Therefore, take electrostatic-sensitive precautions and use suitable tools when cleaning circuit boards and assemblies that are sensitive to electrostatic discharge

—
116
Frame 1 Filter
mat locations

—
117
Frame 2 Filter
mat locations

—
118
Frame 3 Filter
mat locations

Circuit boards should be cleaned with special care using antistatic brushes and a vacuum cleaner with a soft nozzle to prevent component damage.

- Dust inside the cabinet (assemblies, busbars etc.) can be removed with a vacuum cleaner and lint-free cleaning cloths
- Water, oily or greasy deposits on assemblies, components, busbars etc. should be removed with water- and oil-absorbing micro fibers such as “3M Scotch-Brite™”
- Use a nylon brush or a vacuum cleaner to remove dust or deposits from holes
- The outside of the drive enclosure can be cleaned using a vacuum cleaner and cleaning cloths
Do not use alcohol or solvents

Checking wire and cable connections

Vibration can loosen electrical connections and cause occasional malfunction or equipment failure.

Check control cable connections and tighten them if necessary. Check that all plugs and connectors are tight.

Checking and replacing filter mats

Location

The filter mats are located behind the ventilation grills of the INU (1), AFE (2), and Input filter (3) sections.



1	INU
2	AFE
3	Input filter

—
117



1	INU
2	AFE
3	Input filter

—
118



1	INU
2	AFE
3	Input filter

—
116

Checking and replacement indications

Filter mats should be checked regularly. The intervals in which the mats are checked depend on the cleanliness of the cooling air.

The filter mats are monitored by a pressure sensor. When the mats are clogging and the pressure drop reaches the specified final pressure loss, the message **Conv1CoolAirFilter** comes up on the CDP control panel and the alarm/fault pilot light on the control compartment door illuminates.

Replacement

Although checking and removing of a filter mat can be performed during operation of the drive, it is easier to do when the drive is shut down.

When replacing a filter mat while the drive is running, work carefully to prevent foreign matter from entering the drive. Also, pay attention that dust accumulated on the filter mat is not sucked into the cabinet.



Note: ABB recommends removing the old filter mat by rolling it down from the top to the bottom.

Filter mat replacement procedure

Filters can be replaced while the drive is running, as they are accessible from the outside. Caution should be made not to shake filter in front of drive to avoid sucking contaminants into the drive.



CAUTION: While filter grills are finger safe, be aware that components on the inside may be electrically live and action should be taken to avoid contact with tools or fingers.

1. Remove the ventilation grill of the corresponding section.

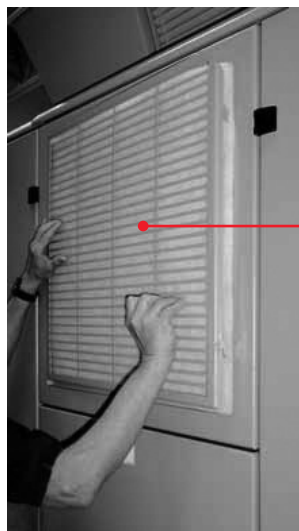

Ventilation grill

The ventilation grills are secured to the cabinet by a channel.

Lift the grill to the slot position and remove.

2. Visually check the filter mat. If the filter mat needs replacement, go on to Step 3. If the mat is clean, replace the grill as in Step 5.
3. Remove the filter mat. Remove the filter mat, being careful not to disturb accumulated dust, by rolling the mat down from the top to the bottom.
4. Install a new filter mat. Use only replacement filter mats of the same filter class, thickness, and size as the original filter mat:
 - Filter class: G3 (EN779)
 - Thickness: approximately 10 mm [0.4 in]
 - ABB supplies replacement filter mats as specified in Table 28

—
Table 28: Filter mat identification

INU and AFE				
Filter mat	ABB replacement part number	Qty	Width mm [in]	Height mm [in]
Frame 1	2UEA001026	2	445 [17.5]	740 [29.0]
Frame 2	2UEA001704	2	830 [32.7]	795 [31.3]
Frame 3	2UEA002487	4	550 [21.7]	795 [31.3]
Input Filter Unit				
Filter mat	ABB replacement part number	Qty	Width mm [in]	Height mm [in]
Frame 1	2UEA001042	1	600 [23.5]	1120 [44.0]
Frame 2	2UEA001694	1	646 [25.4]	610 [24.0]
Frame 3	2UEA001694	1	646 [25.4]	610 [24.0]

Place the new filter mat against the opening. Tuck the edges into the metal frame.

5. Replace the ventilation grill. Clean the grill, removing any dust or accumulated dirt. Position the grill over the door slot and slide into the channel. Lower the grill into place.



6. Completely installed



Replacing a phase module

Overview

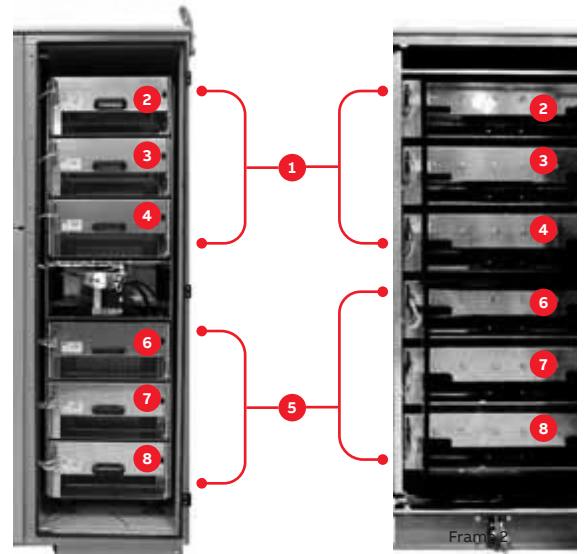

Frame 1

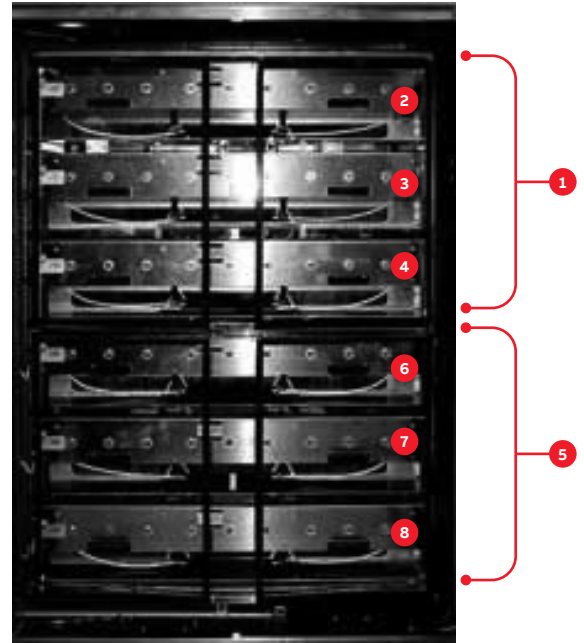

Frame 3

1	INverter Unit (INU)
2	U2 phase module of INU
3	V2 phase module of INU
4	W2 phase module of INU
5	Active Front End (AFE)
6	L1 phase module of AFE
7	L2 phase module of AFE
8	L3 phase module of AFE

Replacement phase modules kits are per frame, not subframe rating and can be used in any location 1-6 above. See Table 29 for replacement part number by frame.



WARNING: Original phase modules shipped with drive should not be interchanged with another unit without contacting ABB for guidance, as they are designed to meet the current requirements of the specific type code listed on the unit.

Dimensions and weight

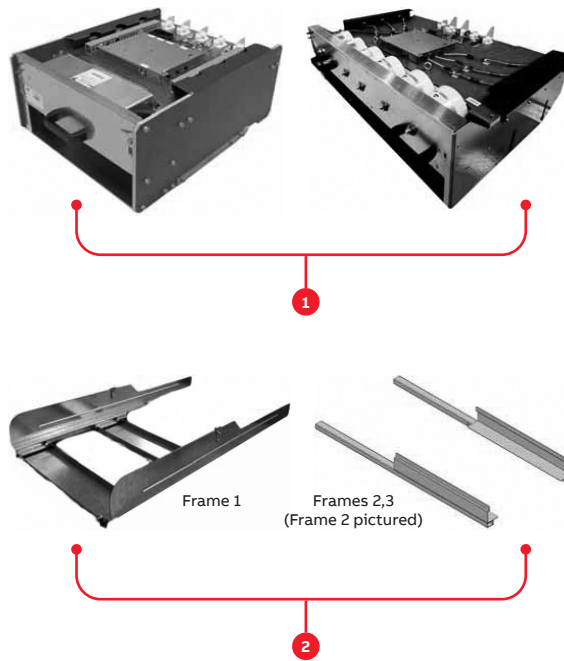

1	Phase module
2	Phase module tool tray

Table 29: Phase module replacement information*

Phase Module	Length mm [in]	Width mm [in]	Height mm [in]	Weight kg [lbs]
Frame 1	628 [24.7]	495 [19.5]	242 [9.5]	35 [77.0]
Frame 2	638 [25.1]	905 [35.6]	256 [10.1]	64 [140]
Frame 3	638 [25.1]	1240 [48.8]	256 [10.1]	210 [463]

*Contact your customer service representative for replacement part numbers

Table 30: Phase module special tools

Frame	Special tools	ABB part number	Comments
1	Tool tray	Comes with phase module kit	Suggest two people
2, 3	Rails (Qty. 2) Hoist lift kit	Comes with phase module kit	Requires lifting hoist and bracket
2, 3		2UEA002561	Not required for Frame 1 phase module replacement

Required tools and accessories

- Phase module tray tool - The phase module tray tool is shipped with the new replacement phase module
- Reversible ratchet with extension
- Phillips, Torx and slotted screwdrivers
- Cable tie
- 10 mm and 13 mm sockets

Phase module replacement procedure



DANGER: Hazardous voltage!

Dangerous voltage is present when input power is connected.

Verify that the main power supply is switched off, locked out and tagged out.

1. Disconnect upstream power using the Kirk® key and perform generally accepted Lockout-Tagout Procedures.



WARNING! Dangerous voltage is present when input power is connected. After disconnecting the supply, wait until the ground RELEASED indicator lights up (to let the intermediate circuit capacitors discharge) before attempting to ground and open the AFE/INU compartment door.

2. Turn the grounding switch to the grounded position.



See Appendix P - Integral input contactor disconnect, located on the CD, for Kirk key location on drives with this option.

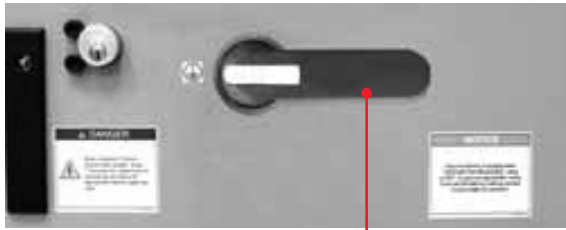

Grounding switch
(shown in grounded position)

3. Identify defective phase module.

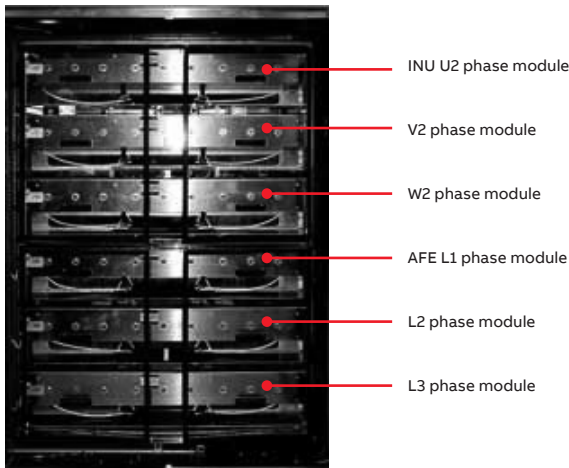
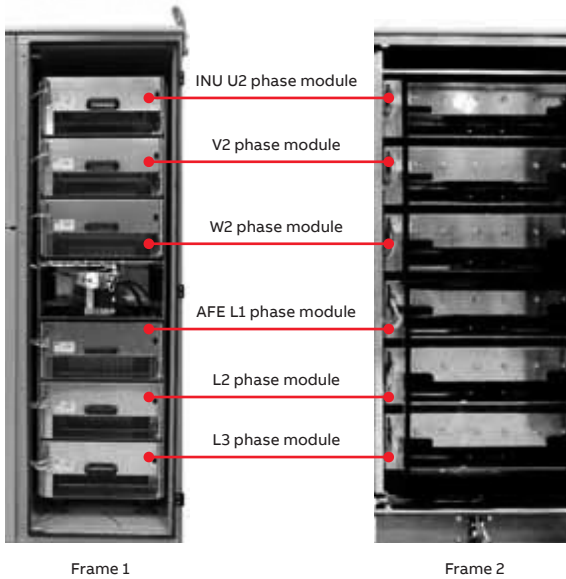

4. Turn off auxiliary power supply to the phase modules. (Q1351)

See Appendix E - Wiring diagrams, located on the CD, to identify the circuit breakers that remove auxiliary power from the drive.



CAUTION: After the circuit breakers have been switched off, the charging transformer and the fan unit are still connected to their power supplies.

5. Remove the plexiglas air plenum by removing the six screws.

- Screw type: M6 socket-head screw
- Required tool: 10 mm socket

When working on the AFE, first pull out the air pressure tube at the bottom of the panel.

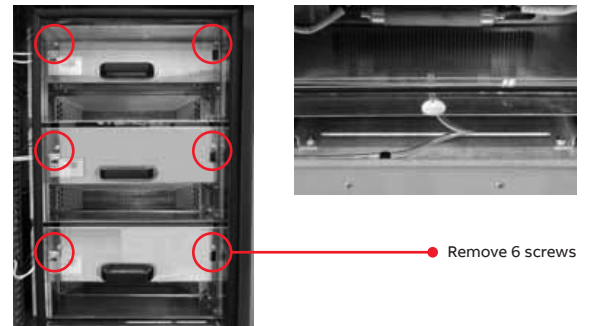

6. Unplug fiber optic cables and control wiring connector from the front of the phase module. Carefully position cables to prevent damaging them when changing the phase module.



7. Remove the screws on the left/right side of the phase module.

- Screw type: M10 socket-head screw
- Required tool: 10 mm socket



Phase module screws

8. Frame 1 - Insert the module tray into the cabinet along the lower sides of the phase module.

- Slide the phase module tray tool in, until it makes contact with the metal flange on both sides of the NP frame



8. Frames 2, 3 - Insert the module tray into the cabinet along the lower sides of the phase module.

- Slide the phase module tray tool in, until it makes contact with the metal flange on both sides of the NP frame and the spring clip engages



9. Hold the phase module by the handle and pull it out slowly until it is flush with the leading edge of the tray.



Note: Verify that the module tray tool is firmly in place during this step.



- Open the securing hinges of the tray tool to firmly attach the tray tool to the drive frame (This prevents any movement of the tray tool while pulling out the phase module.)



CAUTION: Make sure to open the hinges to prevent dropping the phase module and the tray tool.

10. Frame 1 - Lift the phase module off the module tray.

Hold the phase module at the positions indicated by the arrows.



CAUTION: Due to weight of phase module, it is recommended that two people are involved in removal and in the case for Frame 2, the hoist is used. Refer to section Dimensions and weight for details on weights, replacement part numbers and special tools.

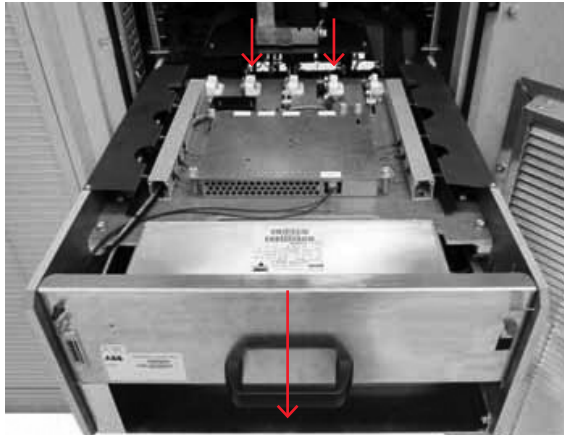

10. Frames 2, 3 - Mount the lifting hoist to the drive per hoist instructions. Hook up the lifting harness at locations shown.

Using the hoist, lift the phase module off the module tray.



11. Place the new module on the tray.

12. Gently push the phase module back into the rack, ensuring cables are not pinched against the cabinet, as far as it goes. Tighten the fastening bolts that secure module to cabinet on each side.



13. Reconnect fiber optic cables and control wires to the phase module.

Be sure to connect the gray fiber optic connector to the gray socket and the blue fiber optic connector to the blue socket.

14. Remove the phase module tray tool.

15. Reinstall the plexiglass air plenum with the six socket-head screws. If an AFE module was replaced, be sure to reinstall air pressure tube in plenum. Failure to do so will result in pressure fault.

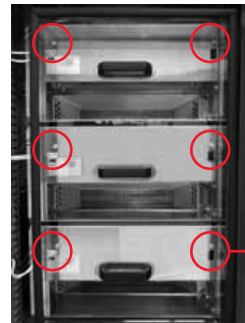

Replace 6 screws

16. Switch on all miniature circuit breakers in the control compartment.

17. Close the compartment door, follow lockout-tagout removal procedures, unground, and start the drive.

See Chapter Local operation, Section Starting the drive system locally if you need information on the start-up procedure.

NOTICE

NOTICE: If you need further assistance, please contact ABB Medium Voltage Drives Technical Support at 1-800-435-7365 Option 4. Please have the serial number of the ACS2000 unit ready for reference. Questions can also be emailed to DriveSupportLine@us.abb.com

18. The failed phase module needs to be returned to ABB after the replacement is complete. See Notice for address.

NOTICE

NOTICE: Parts sent as warranty replacements need to be returned to the address listed below within 30 days from the date of shipment to avoid being charged. Please place the RMA number on the outside of the box.

ABB Inc.
2500 S. Commerce Dr.
New Berlin, WI 53151



—

ABB Inc.

Medium Voltage Drives

16250 W. Glendale Drive

New Berlin, WI 53151

Phone: 800-752-0696

Fax: 262-785-3322

E-Mail: mv.drives.sales@us.abb.com

www.abb.us/drives